

125/200 SX, MXC, EXC

KTM
SPORTMOTORCYCLES

ERSATZTEILKATALOG
MOTOR

SPARE PARTS MANUAL
ENGINE

2003

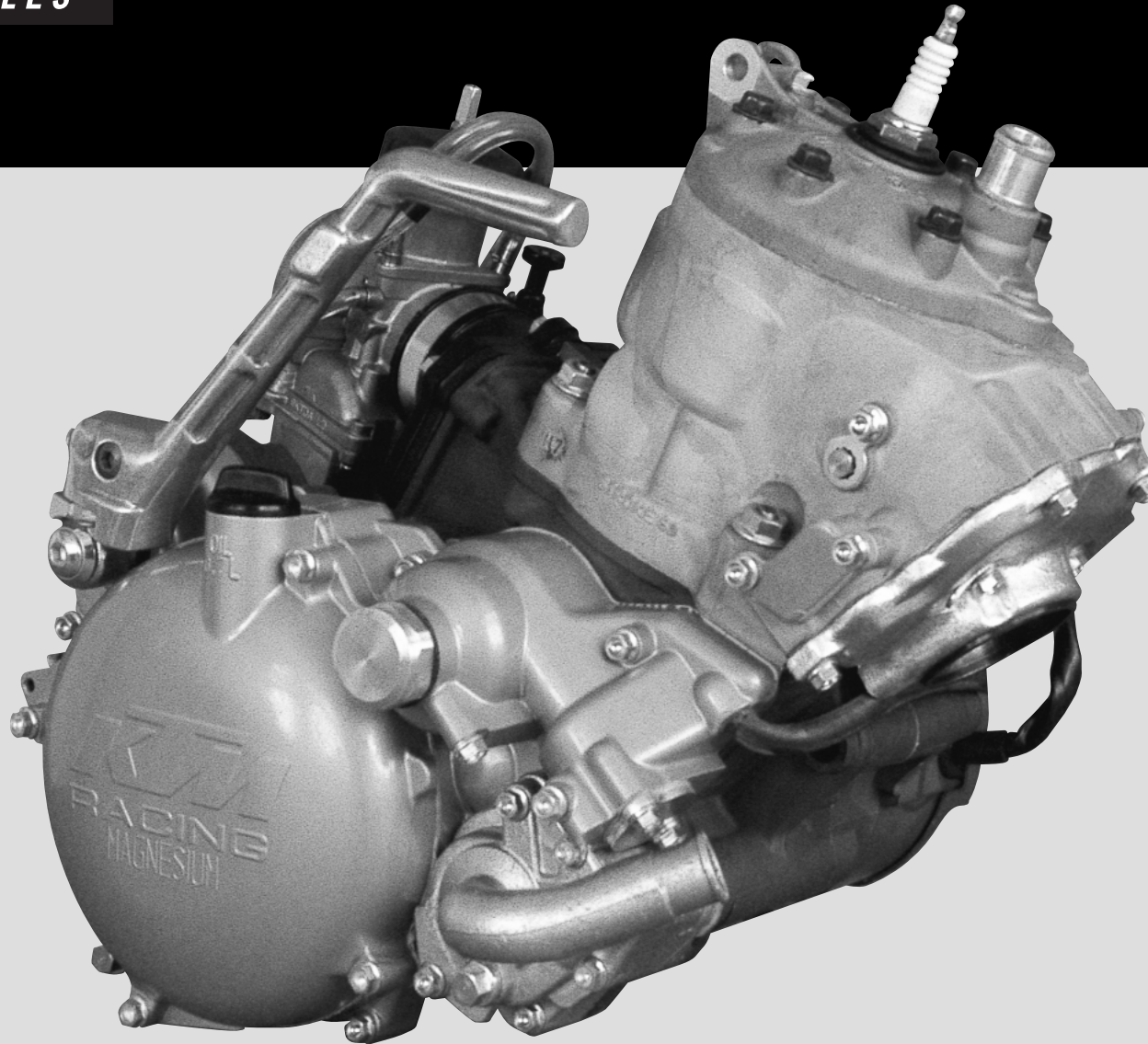

MOTORGEHÄUSE
ENGINE CASE

SEITE
Page
3

5
+ GETRIEBELAGER
TRANSMISSION BEARINGS
(2 x 0625 060087,
1 x 0625 060092, 0625 060040)

MEMBRANGEHÄUSE
REED VALVE CASE

SEITE
Page
4

200 MXC, EXC

KUPPLUNGSDECKEL
CLUTCH COVER

SEITE
Page
5

KURBELWELLE, KOLBEN
CRANKSHAFT, PISTON

SEITE
Page
6

SX MXC, EXC
gegossen cast gegossen cast

ZYLINDER, ZYLINDERKOPF
CYLINDER, CYLINDER HEAD

SEITE
Page
8

AUSLASSTEUERUNG
EXHAUST CONTROL

SEITE
Page
9

STEUERWALZE RECHTS
CONTROL SHAFT R/S
STEUERWALZE LINKS
CONTROL SHAFT L/S

VERGASER KEIHIN PWK 39/38 AG
CARBURETOR KEIHIN PWK 39/38 AG

SEITE
Page
11

ZÜNDANLAGE KOKUSAN
IGNITION SYSTEM KOKUSAN

SEITE
Page
14

2K-1

KUPPLUNG
CLUTCH

SEITE
Page
15

KICKSTARTER
KICKSTARTER

SEITE
Page
16

LOCTITE 243

GETRIEBE I - ANTRIEBSWELLE SX, MXC
TRANSMISSION I - MAIN SHAFT SX, MXC

SEITE
Page
17

GETRIEBE I - ANTRIEBSWELLE EXC
TRANSMISSION I - MAIN SHAFT EXC

SEITE
Page
18

GETRIEBE II - ABTRIEBSWELLE SX, MXC
TRANSMISSION II - COUNTERSHAFT SX, MXC

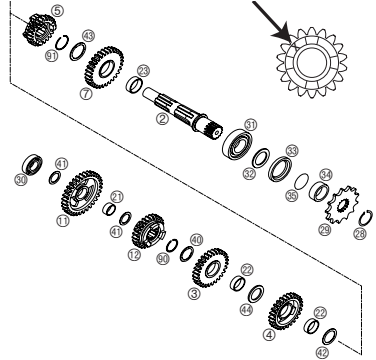

SEITE
Page
19

GETRIEBE II - ABTRIEBSWELLE EXC
TRANSMISSION II - COUNTERSHAFT EXC

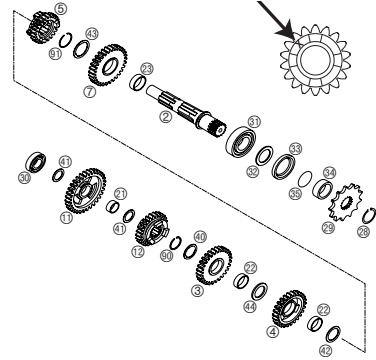

SEITE
Page
20

SCHALTUNG
SHIFTING MECHANISM

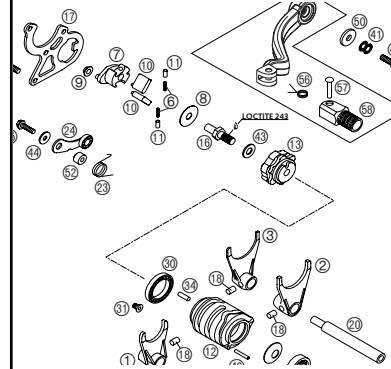

SEITE
Page
21

KÜHLSYSTEM SX, MXC, EXC (USA, AUS)
COOLING SYSTEM SX, MXC, EXC (USA, AUS)

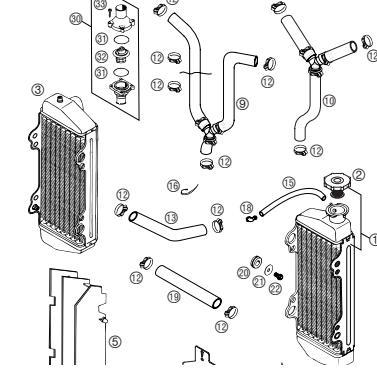

SEITE
Page
23

KÜHLSYSTEM EXC EUROPA
COOLING SYSTEM EXC EUROPE

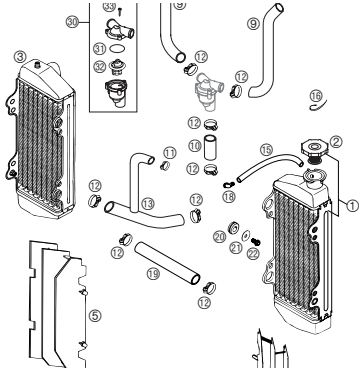

SEITE
Page
24

SPEZIALWERKZEUGE
SPECIAL TOOLS

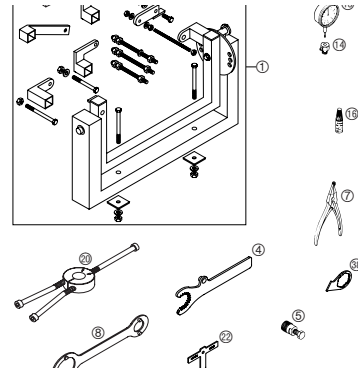

SEITE
Page
25



REG.NO. 12 100 6061

! Die **KTM Sportmotorcycle AG** behält sich das Recht vor, Ausrüstung, technische Angaben, Farben, Materialien, Dienstleistungsangebote, Serviceleistungen und ähnliche Dinge ohne vorheriger Ankündigung und ohne Angabe von Gründen zu ändern bzw. ersatzlos zu streichen, sowie die Fertigung eines bestimmten Modells ohne vorherige Ankündigung einzustellen. Für Druckfehler übernehmen wir keine Haftung.

! **KTM Sportmotorcycle AG** reserves the right to modify any equipment, technical specifications, colors, materials, services offered and rendered, and the like so as to adapt them to local conditions without previous announcement and without giving reasons, or to cancel any of the above items without substituting them with others. It shall be acceptable to stop manufacturing a certain model without previous announcement. In the event of such modifications, please ask your local KTM dealer for information. We shall not be held liable for any printing errors.

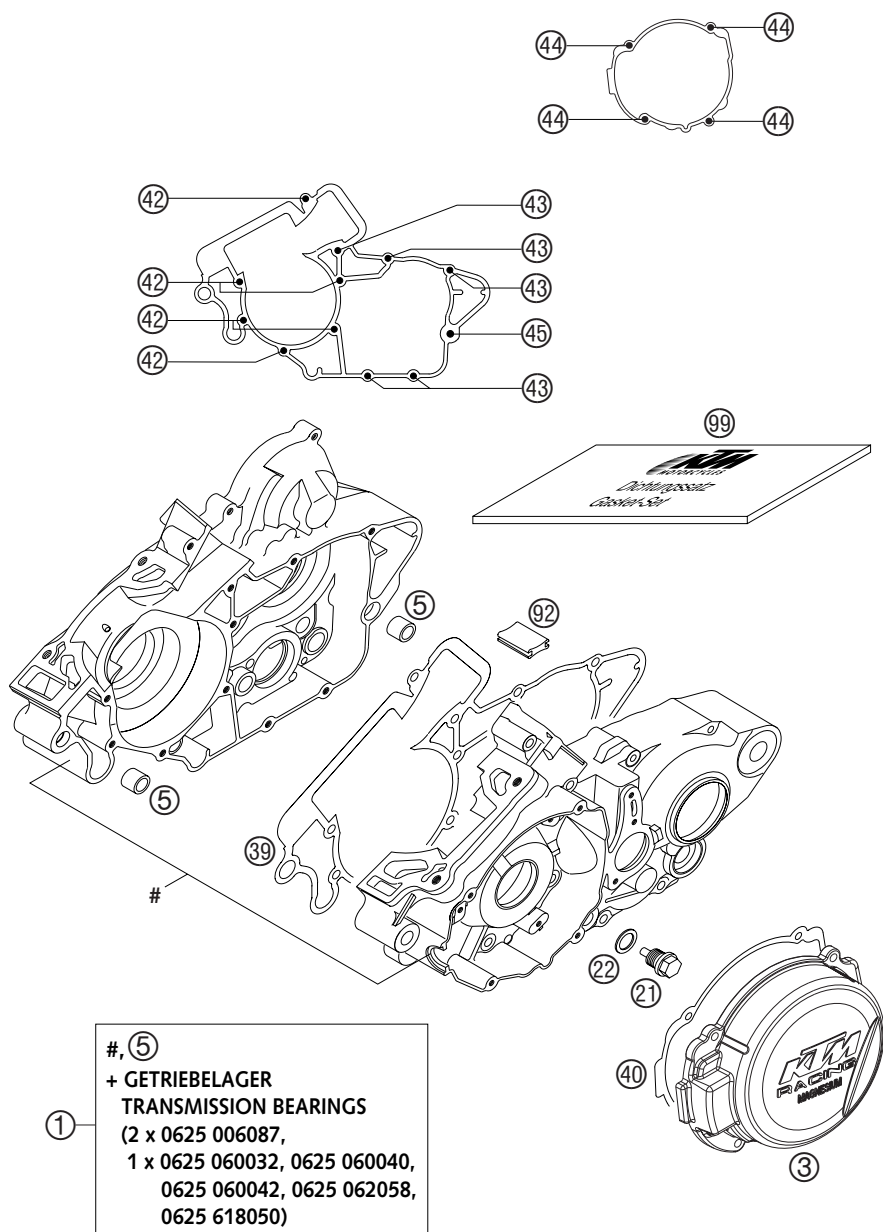
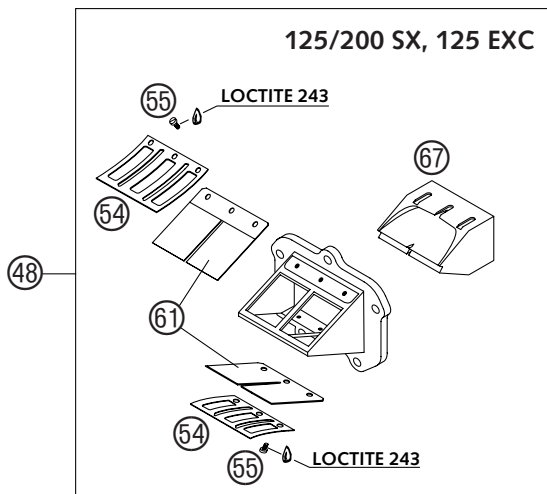

FIG	TEILNR/PARTNR	BEZEICHNUNG	DESCRIPTION	QTY
1*	523.30.000.344	MOTERGEHÄUSE KPL.M.GETR.LAG'03	ENGINE CASE CPL.M.TAN.BEAR'03	1
3	503.30.002.200/98	ZÜNDUNGSDECK.125/200 MAG. 2001	IGNIT.COVER 125/200 MAG. 2001	1
5	546.30.027.000	PASSBÜCHSE 13,8X11X12	DOWEL BUSHING 13,8X11X12	2
21	580.30.021.000	ÖLABLASSCHR.B.M.MAGNET M 12X1,5	OILDRAIN PLUG W.MAG. M 12X1,5	1
22	580.38.022.000	CU-DICHTRING DIN7603-12X18X1,5	CU-SEAL RING DIN7603-12X18X1,5	1
39	503.30.039.000	MOTERGEHÄUSEDICHTUNG 0,5MM '98	ENGINE CASE GASKET 0,5MM '98	1
40	503.30.040.100	ZÜNDUNGSDECKELDICHTUNG 2001	IGNITION COVER GASKET 2001	1
42	0015 060503	SK.BUNDSCHRAUBE M 6X50 SW=8	HH COLLAR SCREW M 6X50 WS=8	6
43	0015 060553	SK.BUNDSCHRAUBE M 6X55 SW=8	HH COLLAR SCREW M 6X55 WS=8	5
44	0015 050163	SK.BUNDSCHRAUBE M 5X16 SW=8	HH COLLAR SCREW M 5X16 WS=8	4
45*	0015 060603	SK.BUNDSCHRAUBE M 6X60 SW=8	HH COLLAR SCREW M 6X60 WS=8	1
92	503.30.092.000	ÖLFÜHRUNGSTÜLLE 25X31 '98	OIL GUARD GROMMET 25X31 '98	1
99	503.30.099.000	DICHTUNGSSATZ 125-200 '98-'01	GASKET SET 125-200 '98-'01	1

#, ⑤
+ GETRIEBELAGER
TRANSMISSION BEARINGS
(2 x 0625 006087,
1 x 0625 060032, 0625 060040,
0625 060042, 0625 062058,
0625 618050)

FIG	TEILNR/PARTNR	BEZEICHNUNG	DESCRIPTION	QTY
48	503.30.051.244	MEMBRANGEHÄUSE KPL.	REED VALVE ASSY CPL. 2000	1
50	523.30.051.144	MEMBRANGEHÄUSE KPL.	REED VALVE ASSY CPL. 2001	1
54	546.30.053.000	ANSCHLAGBLECH	STOP PLATE TOP	2
55	0084 040083	ZYL.SCHRAUBE DIN 84 A M4X8	CYL.HEAD SCREW DIN0084-M 4X8 A	6
58	0137 060003	FEDERSCHEIBE DIN 137 B 6	SPRING WASHER DIN0137-B 6	5
59	0015 060203	SK.BUNDSCHRAUBE M 6X20 SW=8	HH COLLAR SCREW M 6X20 WS=8	5
60	543.30.061.000	SHELLE 52/12 GEMI	CLAMP 52/12 GEMI	1
61	503.30.052.044	MEMBRANE SET 0,44MM	REED VALVE SET 0,44MM 2000	1
66	547.30.052.040	MEMBRANE CARBON 0,4MM '99	REED VALVE CARBON 0,4MM '99	2
67	503.30.054.100	MEMBRANEINSATZ	REED VALVE INSERT 2000	1
68	503.30.050.200	ANSAUGFLANSCH	INTAKE FLANGE 2000	1

125/200 SX, 125 EXC



200 MXC, EXC

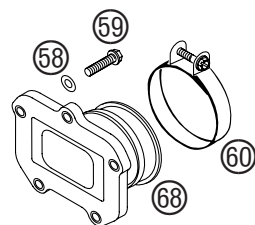
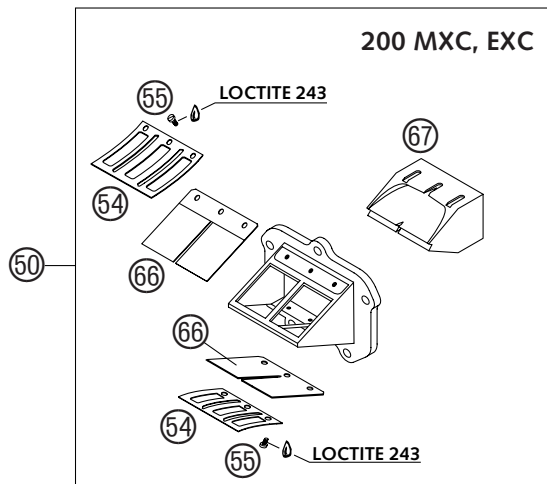
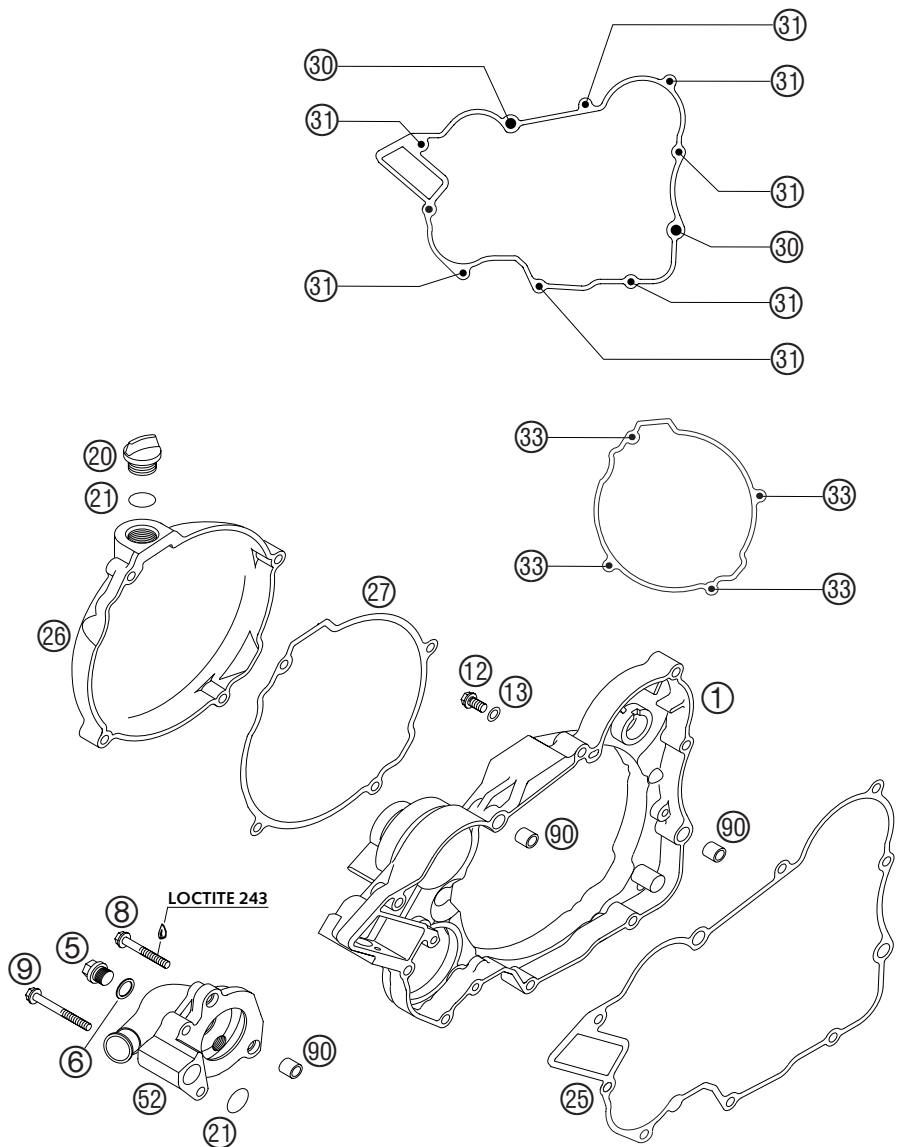

FIG	TEILNR/PARTNR	BEZEICHNUNG	DESCRIPTION	QTY
1	503.30.001.144/98	KUPPLUNGSDECKEL KPL.125/200 02	CLUTCH COVER CPL.125/200 02	1
5	0910 100003	VERSCHL.SCHR.DIN0910-M 10X1	PLUG DIN0910-M 10X1	1
6	420.13.226.000	CU-DICHTRING DIN7603-10X16X1	CU-SEAL RING DIN7603-10X16X1	1
8	0015 060353	SK.BUNDSCHRAUBE M 6X35 SW=8	HH COLLAR SCREW M 6X35 WS=8	2
9	0015 060503	SK.BUNDSCHRAUBE M 6X50 SW=8	HH COLLAR SCREW M 6X50 WS=8	2
12	0015 060123	SK.BUNDSCHRAUBE M 6X12 SW=8	HH COLLAR SCREW M 6X12 WS=8	1
13	0603 061001	CU-DICHTRING DIN7603-6X10X1	CU-SEAL RING DIN7603-6X10X1	1
20	580.30.020.000	ÖLEINFÜLLSCHRAUBE M 24X3	PLUG M 24X3	1
21	0770 160030	O-RING 16,00X3,00 NBR 70	O-RING 16,00X3,00 NBR 70	2
25	503.30.025.000	KUPPLUNGSDECKELDICHTUNG 0,5MM	CLUTCH COVER GASKET 0,5MM	1
26	503.30.026.000/98	KUPPL.AUSSENDECK. 125/200 2001	CLUTCH OUTS.COVER 125/200 2001	1
27	503.30.027.000	KUPPL.AUSSENDECK. DICHTUNG 1MM	CLUTCH OUTS.COVER GASKET 1MM	1
30	0015 060403	SK.BUNDSCHRAUBE M 6X40 SW=8	HH COLLAR SCREW M 6X40 WS=8	2
31	0015 060353	SK.BUNDSCHRAUBE M 6X35 SW=8	HH COLLAR SCREW M 6X35 WS=8	7
33	0015 060253	SK.BUNDSCHRAUBE M 6X25 SW=8	HH COLLAR SCREW M 6X25 WS=8	4
52	503.35.052.000	WASSERPUMPENDECKEL 125/200 '98	WATER PUMP COVER 125/200 '98	1
90	490.30.090.000	PASSHÜLSE 9,8 X 7 X 10	DOWEL 9,8 X 7 X 10	4



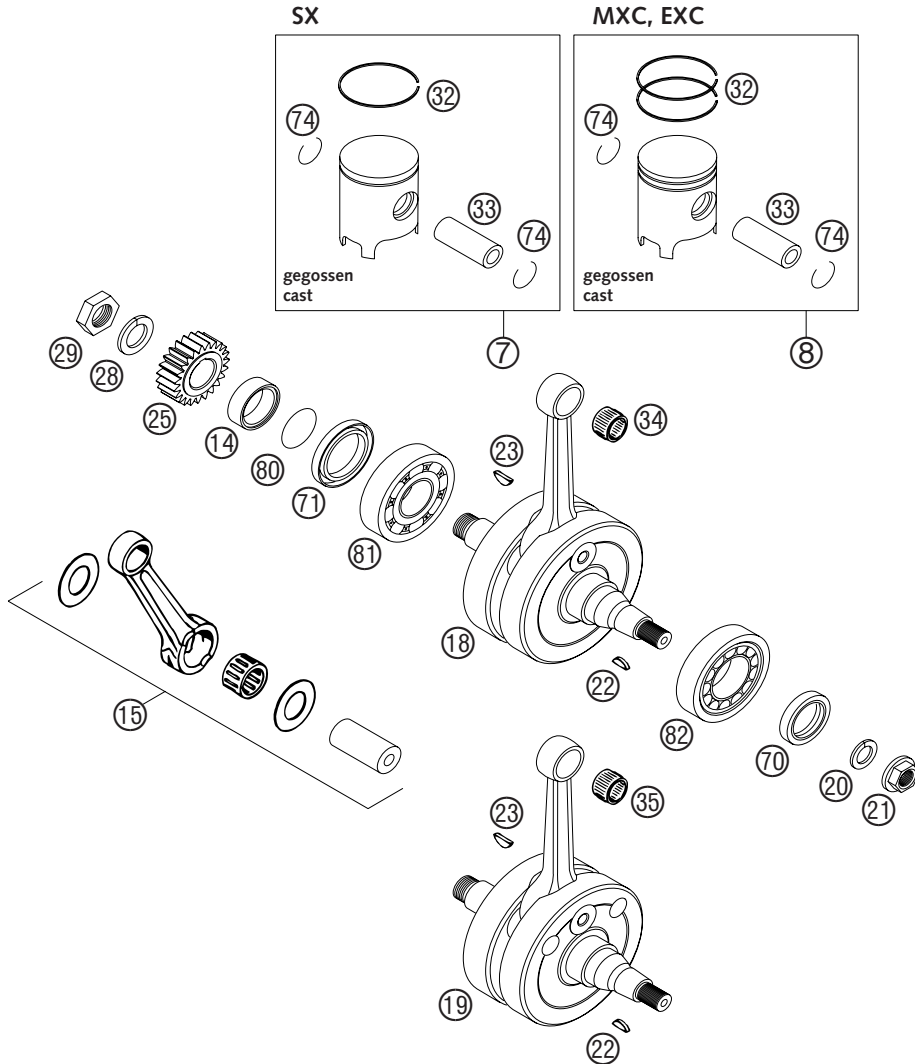

FIG	TEILNR/PARTNR	BEZEICHNUNG	DESCRIPTION	QTY
7	503.30.007.500/ I	KOLBEN I KPL. 54MM 125 2001	PISTON I CPL. 54MM 125 2001	1
7	503.30.007.500/ II	KOLBEN II KPL.54MM 125 2001	PISTON II CPL.54MM 125 2001	1
7*	523.30.007.200/ I	KOLBEN I KPL. 64MM 200 2003	PISTON I CPL. 64MM 200 2003	1
7*	523.30.007.200/ II	KOLBEN II KPL.64MM 200 2003	PISTON II CPL.64MM 200 2003	1
8	503.30.007.400/ I	KOLBEN I KPL. 54MM 125 2000	PISTON I CPL. 54MM 125 2000	1
8	503.30.007.400/ II	KOLBEN II KPL.54MM 125 2000	PISTON II CPL.54MM 125 2000	1
8	523.30.007.100/ I	KOLBEN I KPL. 64MM 200 2000	PISTON I CPL. 64MM 200 2000	1
8	523.30.007.100/ II	KOLBEN II KPL.64MM 200 2000	PISTON II CPL.64MM 200 2000	1
14	546.33.014.100	DISTANZBÜCHSE 12MM	SPACER BUSHING 12MM	1
15	503.30.015.000	PLEUEL-REP.SATZ 125'98	CON.ROD REPAIR KIT 125'98	1
15	523.30.015.000	PLEUEL-REP.SATZ 200'98	CON.ROD REPAIR KIT 200'98	1
18	503.30.018.100	KURBELWELLE 125 EXE/EXC 2001 HUB 54,5	CRANKSHAFT 125 EXE/EXC 2001 STROKE 54,5	1
18	503.30.018.200	KURBELWELLE 125 SX 2001 HUB 54,5	CRANKSHAFT 125 SX 2001 STROKE 54,5	1
19*	523.30.018.100	KURBELWELLE 200 SX,MXC,EXC 03 HUB 60	CRANKSHAFT 200 SX,MXC,EXC 03 STROKE 60	1
20	502.30.029.012	SPERRKANTRING VSK 12	LOCKING RING VSK 12	1
21	490.30.021.000	BUNDMUTTER M12X1 RECHTS	COLLAR NUT M12X1 R/S	1
22	0888 030050	SCHEIBENFEDER DIN6888-3X5X13	WOODRUFF KEY DIN6888-3X5X13	1
23	6 946 005	SCHEIBENFEDER 5X6,5 GEHÄRTET	WOODRUFF KEY 5X6,5 HARDED	1
25	503.32.023.023	PRIMÄRRITZEL 23-Z 125/200'98	PRIMARY PINION 23-T 125/200'98	1
28	502.30.029.016	SPERRKANTRING VSK 16	LOCKING RING VSK 16	1
29	503.30.029.000	SK-MUTTER M 16 X 1,5 - LINKS	HEXAGON NUT M 16 X 1,5 - L/S	1
32	503.30.032.500	RECHTECKRING 54X1 125 2001	SQUARE RING 54X1 125 2001	1(2)
32*	523.30.032.100	RECHTECKRING 64X1 200 2002	SQUARE RING 64X1 200 2002	1(2)
33	503.30.033.500	KOLBENBOLZEN 15X45,2 125 2001	PISTON PIN 15X45,2 125 2001	1
33*	523.30.033.100	KOLBENBOLZEN 11X16X46 200 02	PISTON PIN 11X16X46 200 02	1
34	510.30.034.000	NADELKRANZ KBK 15X19X20 125	NEEDLE BEARING KBK 15X19X20 125	1
35	523.30.034.000	NADELKRANZ KV16X20X20 FN 200	NEEDLE BEARING KV16X20X20 FN 200	1
70	0760 253570	WELLENDICHTRING 25X35X7 BTSL	SHAFT SEAL RING 25X35X7 BTSL	1
71	0760 324564	WELLENDICHTRING 32X45X6,5 BT	SHAFT SEAL RING 32X45X6,5 BT	1
74	503.30.074.500	DRAHTSPRENGRING 15X1 125	WIRE LOCK RING 15X1 125	2

FIG	TEILNR/PARTNR	BEZEICHNUNG	DESCRIPTION	QTY
74*	523.30.074.100	DRAHTSPRENGRING 16X1,2 200	WIRE LOCK RING 16X1,2 200	2
80	0770 250020	O-RING 25,00X2,00 NBR 70	O-RING 25,00X2,00 NBR 70	1
81	0625 063055	RILLENKUGELLAGER 6305 JR2 CS36	BALL BEARING 6305 JR2 CS36	1
82	503.30.082.000	ZYLINDERR.LAGER NJ206 ET2XCS46	CYL.ROLLER BEAR.NJ206 ET2XCS46	1

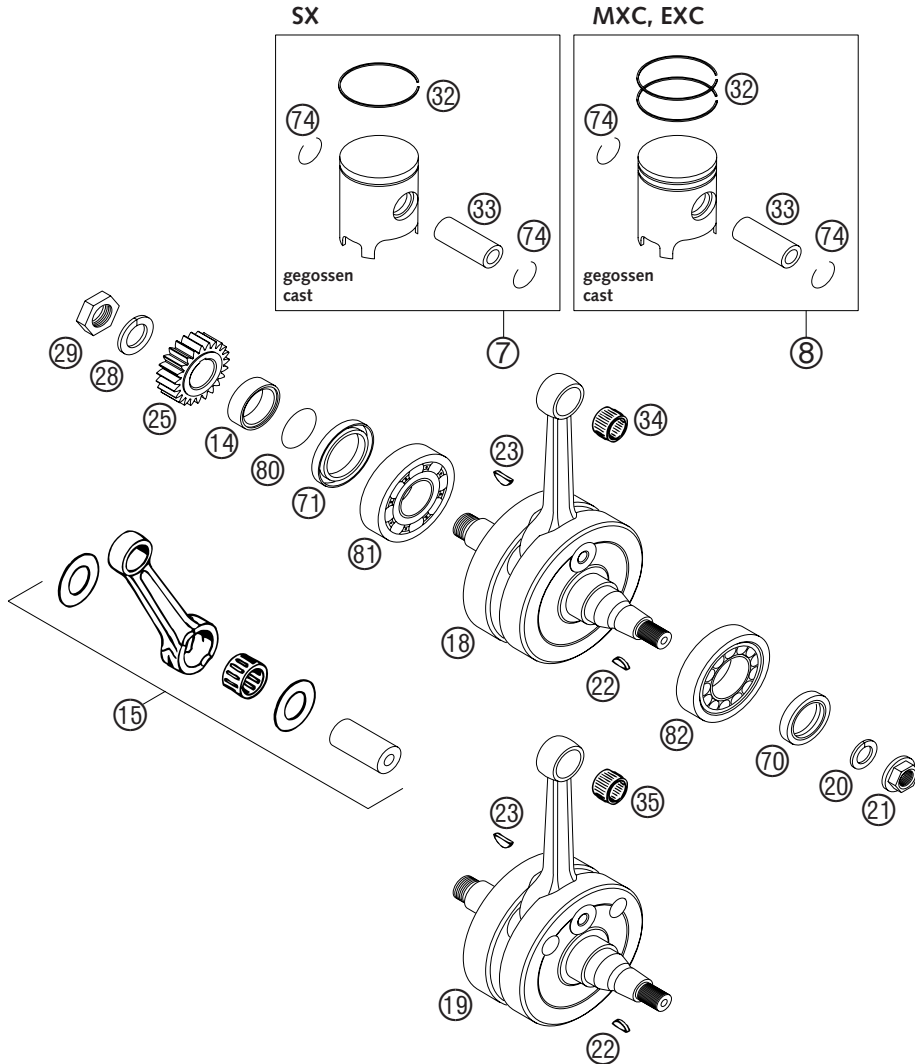
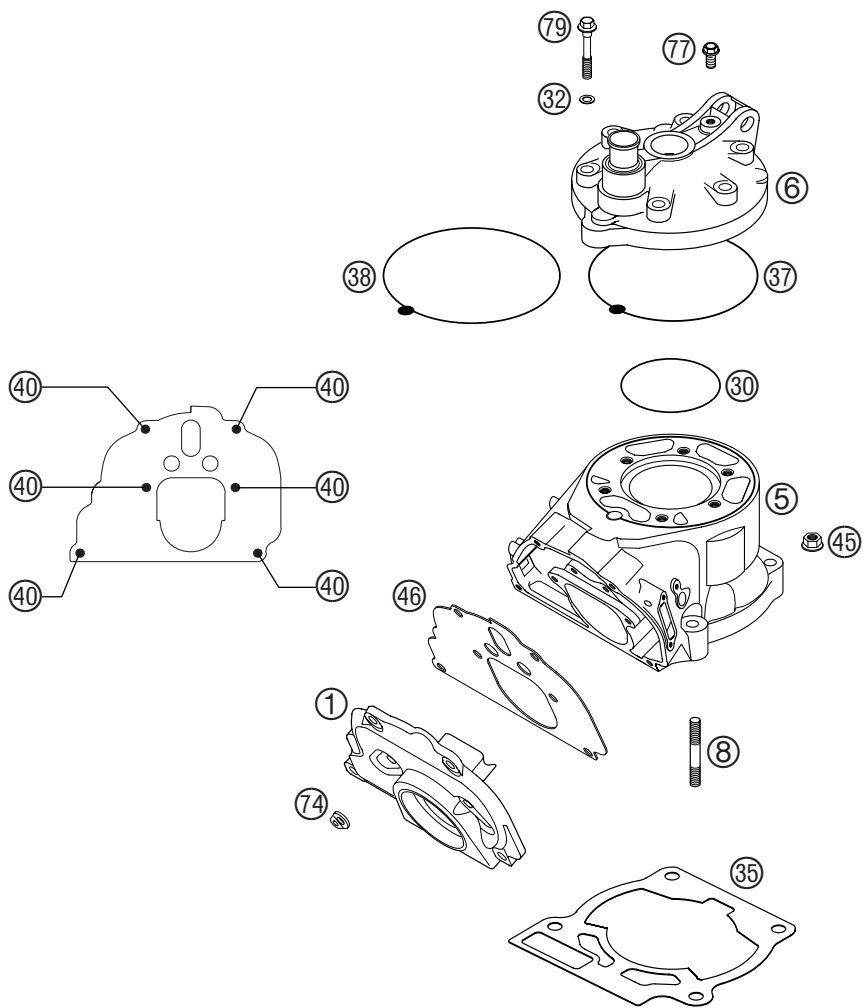

FIG	TEILNR/PARTNR	BEZEICHNUNG	DESCRIPTION	QTY
1	503.37.001.100	ZWISCHENFLANSCH 125 2000	INTERMEDIATE FLANGE 125 2000	1
1	523.37.001.200	ZWISCHENFLANSCH 200 2000	INTERMEDIATE FLANGE 200 2000	1
5	503.30.005.300	ZYLINDER 125 2002	CYLINDER 125 2002	1
5*	523.30.005.300	ZYLINDER 200 2003	CYLINDER 200 2003	1
6	503.30.006.400	ZYLINDERKOPF 125 SX/EXC 2002	CYLINDER HEAD 125 SX/EXC 2002	1
6*	523.30.006.100	ZYLINDERKOPF 200 2003	CYLINDER HEAD 200 2003	1
8	0835 080273	STIFTSCHR. DIN0835-M 8X27 125	STUD DIN0835-M 8X27 125	4
8	0835 080355	STIFTSCHR. DIN0835-M 8X35 10.9 200	STUD DIN0835-M 8X35 10.9 200	4
30	0770 062020	O-RING 62,00X2,00 VITON 125	O-RING 62,00X2,00 VITON 125	1
30	0770 720021	O-RING 72,00X2,00 VITON 200	O-RING 72,00X2,00 VITON 200	1
32	502.30.032.010	CU-DICHTRING 7,3 X 12 X 0,5	CU-SEAL RING 7,3 X 12 X 0,5	6
35	503.30.035.007	ZYL.FUSSDICHT. 0,07MM PAPIER	CYL.BASE GASKET 0,07MM PAPER	X
35	503.30.035.015	ZYLINDERFUSSDICHTUNG 0,15MM	CYLINDER BASE GASKET 0,15MM	X
35	503.30.035.020	ZYLINDERFUSSDICHTUNG 0,20MM	CYLINDER BASE GASKET 0,20MM	X
35	503.30.035.025	ZYLINDERFUSSDICHTUNG 0,25MM	CYLINDER BASE GASKET 0,25MM	X
35	503.30.035.040	ZYLINDERFUSSDICHTUNG 0,40MM	CYLINDER BASE GASKET 0,40MM	X
35	503.30.035.050	ZYLINDERFUSSDICHTUNG 0,50MM	CYLINDER BASE GASKET 0,50MM	X
35	503.30.035.075	ZYLINDERFUSSDICHTUNG 0,75MM	CYLINDER BASE GASKET 0,75MM	X
37	503.30.137.000	ZYL.KOPFDICHTRING 125 2002	CYL.HEAD SEAL RING 125 2002	1
38*	523.30.137.000	ZYL.KOPFDICHTRING 200 2003	CYL.HEAD SEAL RING 200 2003	1
40	0015 050203	SK.BUNDSCHRAUBE M 5X20 SW=8	HH COLLAR SCREW M 5X20 WS=8	6
45	503.30.045.000	SK-BUNDMUTTER M 8 SW=12	HH COLLAR NUT M 8 WS=12	4
46	503.37.046.100	ZW.FLANSCHDICHT.1,1MM 125 2000	INTERMED.GASKET 1,1MM 125 2000	1
46	523.37.046.100	ZW.FLANSCHDICHT.1,1MM 200 2000	INTERMED.GASKET 1,1MM 200 2000	1
74	510.05.074.000	FEDERLASCHE	RETAINING PLATE	2
77*	0015 060103	SK.BUNDSCHRAUBE M 6X10 SW=8	HH COLLAR SCREW M 6X10 WS=8	1
79	500.30.079.000	ZYL.KOPFSCHRAUBE M 7X40 SW=10	CYL. HEAD BOLT M 7X40 WS=10	6



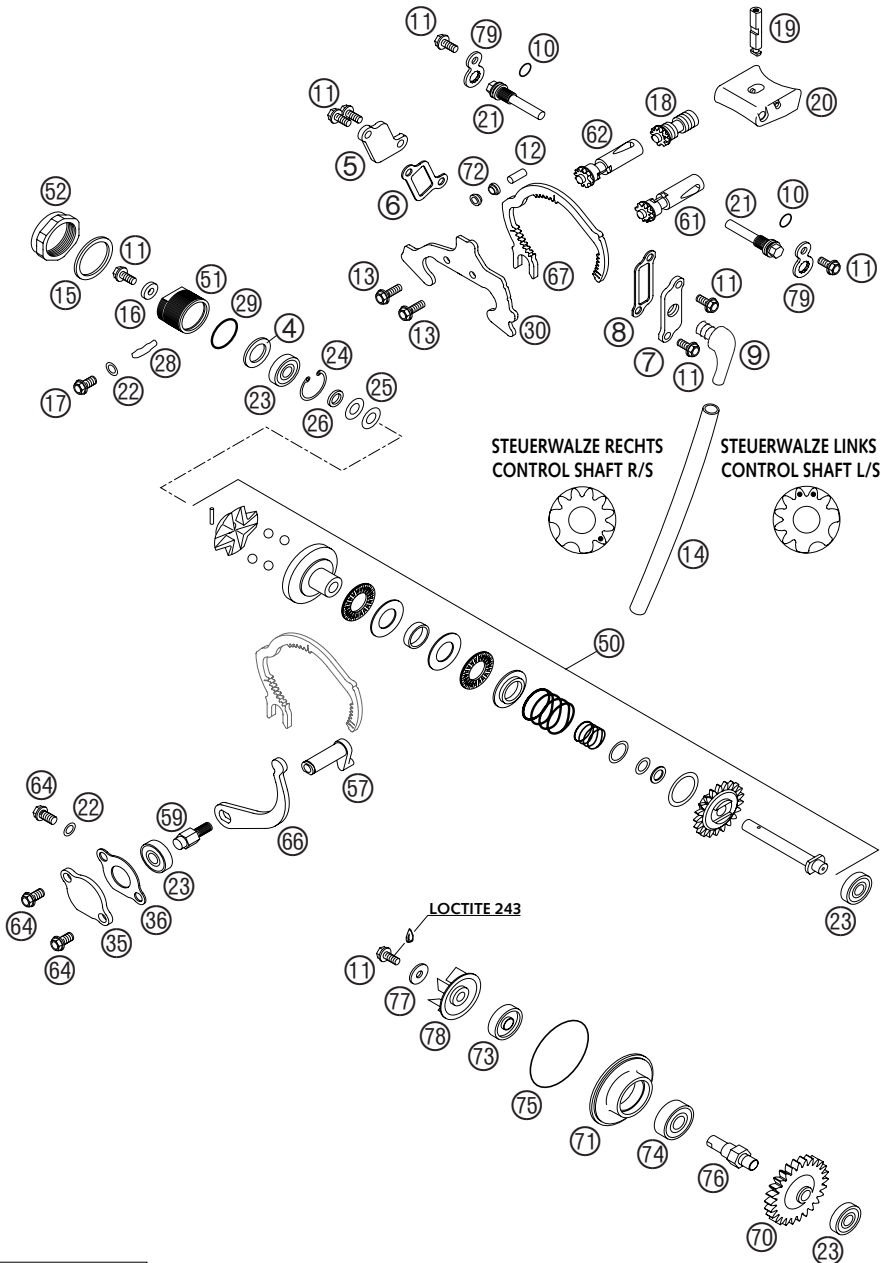

FIG	TEILNR/PARTNR	BEZEICHNUNG	DESCRIPTION	QTY
4	490.33.031.015	ANLAUFSCHIEBE 14,2X22X1,5	STOP DISK 14,2X22X1,5	1
5	503.37.005.000	SEITENDECKEL RECHTS '98	SIDE COVER R/S '98	1
6	503.37.006.000	DICHTUNG SEITENDECKEL RECHTS	GASKET SIDE COVER R/S	1
7	503.37.007.100	SEITENDECKEL LINKS M10 2002	SIDE COVER LEFT M10 2002	1
8	503.37.008.000	DICHTUNG SEITENDECKEL LINKS	GASKET SIDE COVER L/S	1
9	503.30.022.000	WINKELSTÜCK 90 GRAD M10X1 02	ANGLE PIEC 90 DEGREE M10X1 02	1
10	0770 008020	O-RING 8,00X2,00 NBR	O-RING 8,00X2,00 NBR	2
11	0015 050123	SK.BUNDSCHRAUBE M 5X12 SW=8	HH COLLAR SCREW M 5X12 WS=8	8
12	0402 051600	NADELROLLE DIN5402 NRB 5X15,8	NEEDLE ROL. DIN5402 NRB 5X15,8	3
13	0015 050163	SK.BUNDSCHRAUBE M 5X16 SW=8	HH COLLAR SCREW M 5X16 WS=8	2
14	310.07.107.001	PVC-SCHLAUCH 6X9 MM PER METER	PVC-HOSE 6X9 MM PER METRE	0,17
15	0603 262322	CU-DICHRING DIN7603-26X32X2	CU-SEAL RING DIN7603-26X32X2	1
16	503.37.050.064	SCHEIBE 5,2 X 12 X 3	WASHER 5,2 X 12 X 3	1
17	0015 060103	SK.BUNDSCHRAUBE M 6X10 SW=8	HH COLLAR SCREW M 6X10 WS=8	1
18	503.37.018.044	EXZENTER FÜR HUBBOLZEN 125'98	ECCENTRIC FOR CRANKBOLT 125'98	1
18	523.37.018.044	EXZENTER FÜR HUBBOLZEN 200'98	ECCENTRIC FOR CRANKBOLT 200'98	1
19	503.37.019.000	HUBBOLZEN FÜR STEUERKL. 125'98	CRANK BOLT F.CONTROL FL.125'98	1
19	523.37.019.000	HUBBOLZEN FÜR STEUERKL. 200'98	CRANK BOLT F.CONTROL FL.200'98	1
20	503.37.020.144	STEUERKLAPPE 125 2002	CONTROL FLAP 125 2002	1
20	523.37.020.000	STEUERKLAPPE 200'98	CONTROL FLAP 200'98	1
21	503.37.021.000	ACHSE F. STEUERKLAPPE SW=8 '98	AXLE FOR CONTROL FLAP WS=8 '98	2
22	0603 061001	CU-DICHRING DIN7603-6X10X1	CU-SEAL RING DIN7603-6X10X1	2
23	0625 006087	RILLENKUGELLAGER 608 2RS C3	GROOVED BALL BEAR. 608 2RS C3	4
24	0472 022100	SICHERUNGSRING DIN0472-22X1	CIRCLIP DIN0472-22X1	1
25	0093 821606	TELLERFEDER DIN2093-8,2X16X0,6	WASHER DIN2093-8,2X16X0,6	2
26	503.37.050.063	DISTANZHÜLSE 8X12X2,3	SPACER BUSHING 8X12X2,3	1
28	000.99.300.011	O-RINGSCHNUR 4MM NBR 70 PER/M	O-RINGSTRING 4MM NBR 70 PER/M	0,018
29	0770 160030	O-RING 16,00X3,00 NBR 70	O-RING 16,00X3,00 NBR 70	1
30	503.37.030.000	FÜHRUNGSBLECH 3MM 125'98	SHEET METAL GUIDE 3MM 125'98	1
30	523.37.030.000	FÜHRUNGSBLECH 3MM 200'98	SHEET METAL GUIDE 3MM 200'98	1
35	503.37.035.000	VERSCHLUSSDECKEL '98	CLOSING COVER '98	1
36	503.37.035.050	VERSCHLUSSDECKELDICHTUNG 1MM	CLOSING COVER GASKET 1MM	1
50	503.37.050.044	FLIEHKRAFTVERSTELL. KPL.125'98 125/200 SX, 125 EXC	CENTRIFUGAL TIMER CPL. 125'98 125/200 SX, 125 EXC	1
50	523.37.050.044	FLIEHKRAFTVERSTELL. KPL.200'98 200 MXC, EXC	CENTRIFUGAL TIMER CPL. 200'98 200 MXC, EXC	1

* = NEUTEIL / NEW PART

X = NACH BEDARF / AS REQUIRED

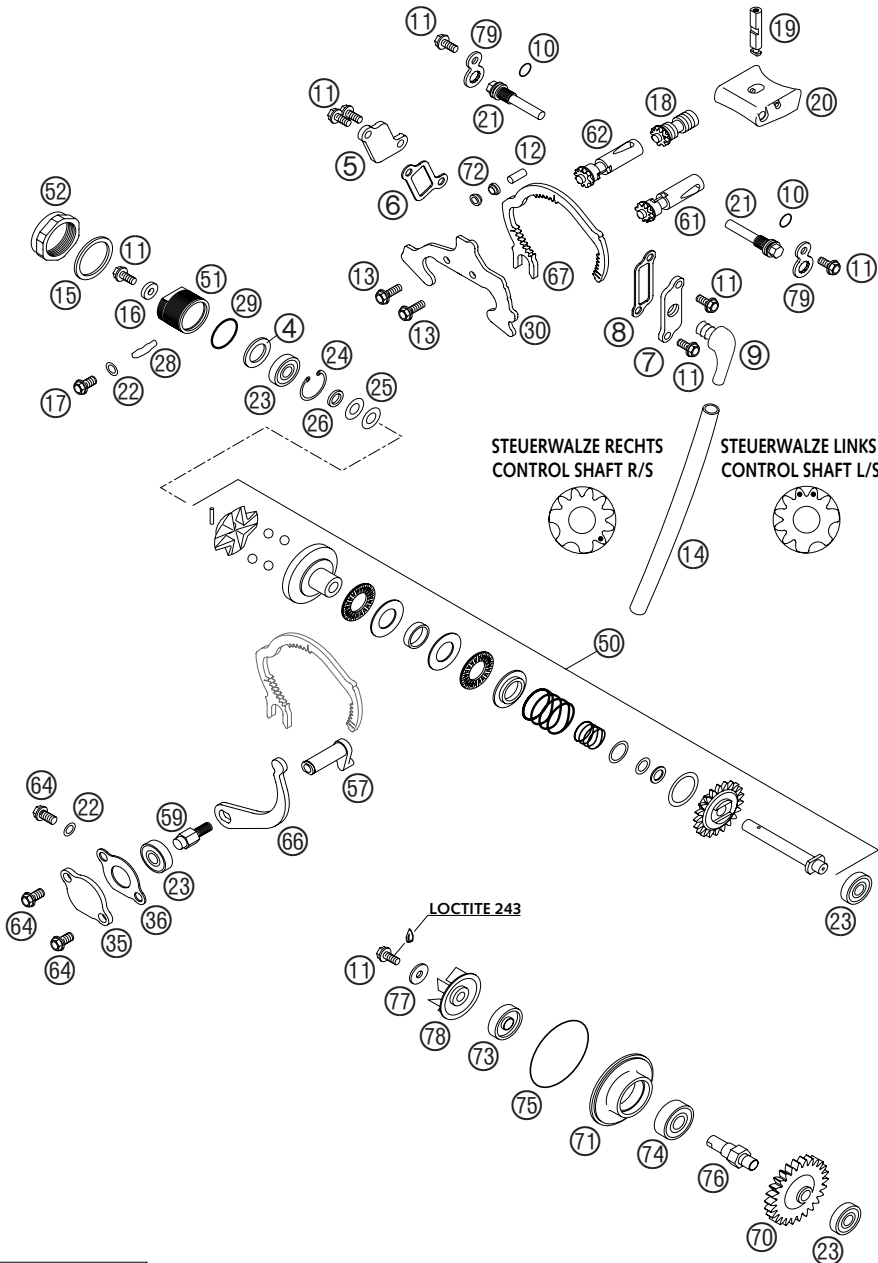

FIG	TEILNR/PARTNR	BEZEICHNUNG	DESCRIPTION	QTY
51	503.37.050.062	LAGERHALTER M 26X1 '98	BEARING HOLDER M 26X1 '98	1
52	503.37.050.061	VERSCHLUSSMUTTER M 26X1 SW=30	CLOSING NUT M 26X1 WS=30	1
57	503.37.057.000	VERSTELLHEBEL 125/200'98	CONTROL LEVER 125/200'98	1
59	503.37.059.000	VERSTELLWELLE M 6 SW=10 '98	CONTROL SHAFT M 6 WS=10 '98	1
61	503.37.061.144	STEUERWALZE KPL. LI. 125 2001	CONTROL SHAFT CPL.L/S 125 2001	1
61	523.37.061.144	STEUERWALZE KPL. LI. 200 2001	CONTROL SHAFT CPL.L/S 200 2001	1
62	503.37.062.144	STEUERWALZE KPL. RE. 125 2001	CONTROL SHAFT CPL.R/S 125 2001	1
62	523.37.062.144	STEUERWALZE KPL. RE. 200 2001	CONTROL SHAFT CPL.R/S 200 2001	1
64	0015 060123	SK.BUNDSCHRAUBE M 6X12 SW=8	HH COLLAR SCREW M 6X12 WS=8	3
66	503.37.066.000	WINKELHEBEL F.STEUERW.SEGM.'98	LEVER F. CONTROL SEGMENT '98	1
67	503.37.067.000	STEUERWALZENSEGMENT 125'98	CONTROL SHAFT SEGMENT 125'98	1
67	523.37.067.000	STEUERWALZENSEGMENT 200'98	CONTROL SHAFT SEGMENT 200'98	1
70	503.35.054.026	ANTRIEBSRAD 26-Z 125/200'98	DRIVE WHEEL 26-T 125/200'98	1
71	503.35.056.000	LAGERTRÄGER WASSERPUMPE '98	BEARING SUPPORT WATER PUMP '98	1
72	503.37.072.000	FÜHRUNGSRÖLLE 5X6,1X8X4 '98	ROLLER GUIDE 5X6,1X8X4 '98	6
73	0760 082472	WELLENDICHTRING 8X24X7 A DUO	SHAFT SEAL RING 8X24X7 A DUO	1
74	0625 060001	RILLENKUGELLAGER 6000/C3	BALL BEARING 6000/C3	1
75	0770 049025	O-RING 49,00X2,50 NBR	O-RING 49,00X2,50 NBR	1
76	503.35.054.050	WASSERPUMPENWELLE 125/200'98	WATER PUMP SHAFT 125/200'98	1
77	0349 000050	SCHEIBE DIN7349-5X15X2	WASHER DIN7349-5X15X2	1
78	546.35.005.000	WASSERPUMPENRAD	WATER PUMP WHEEL	1
79	503.37.079.000	SICHERUNGSBLECH 2MM '98	LOCK METAL SHEET 2MM '98	2

ACHTUNG !!!
Vor dem Einbau des Vergasers, Bedüsung kontrollieren.
CAUTION !!!
Before mounting the carburetor, check the jetting.

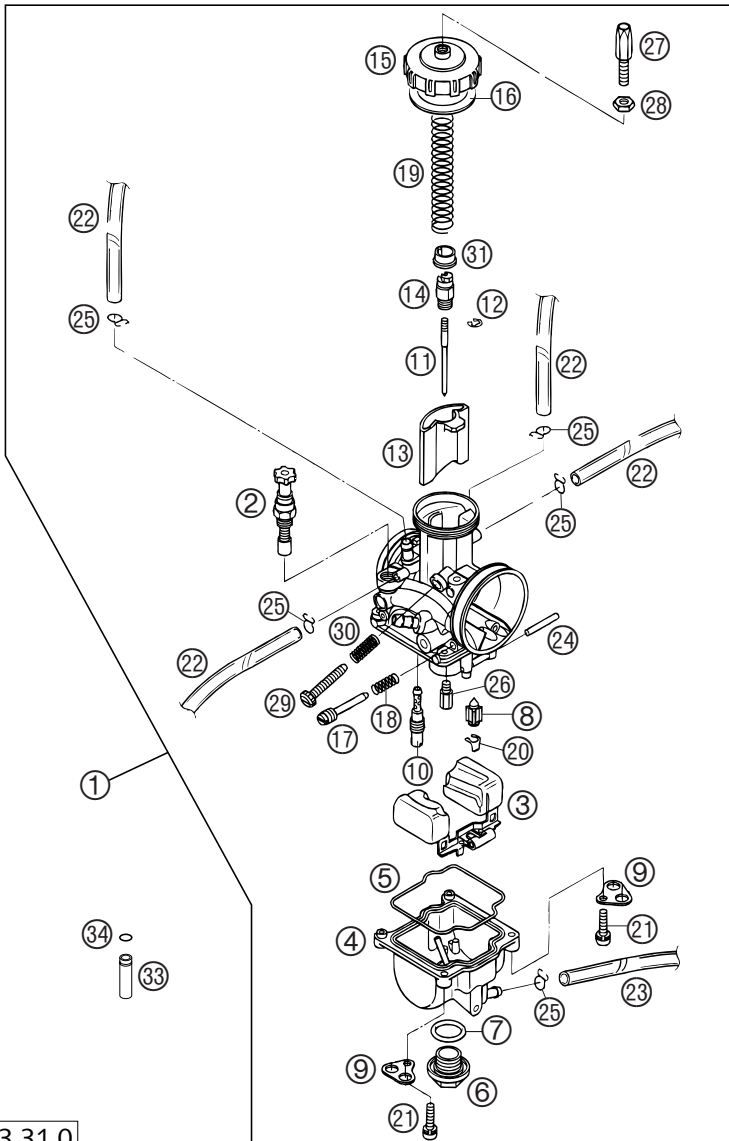
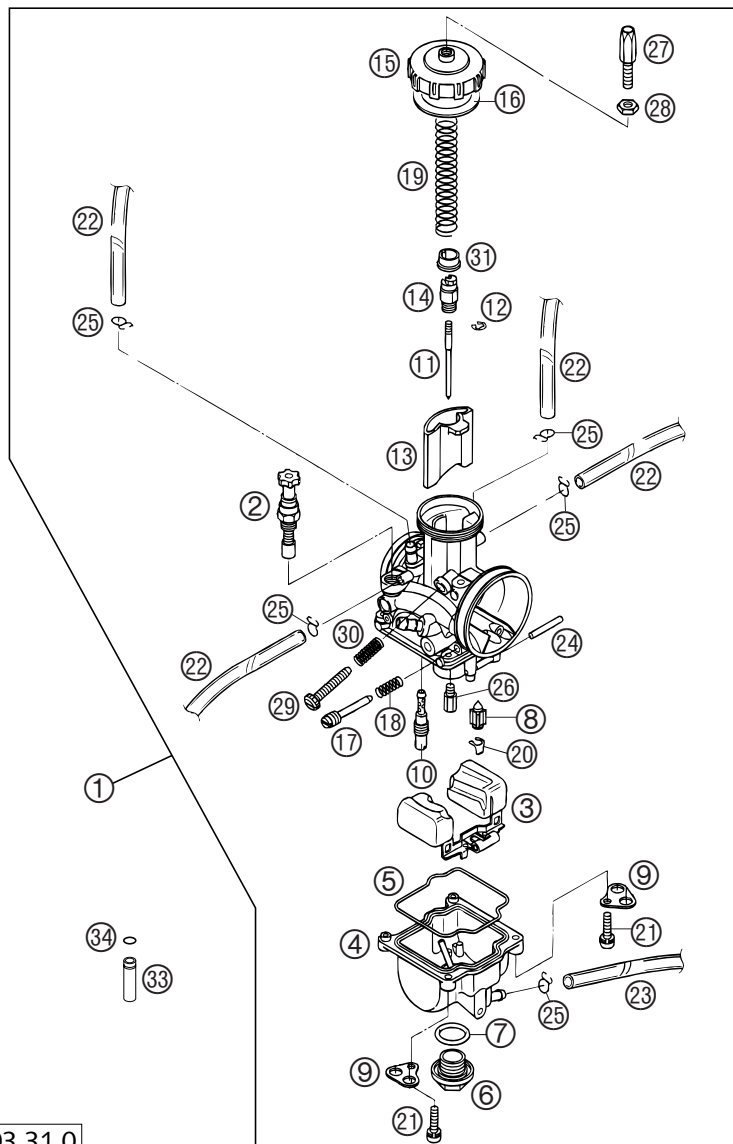

FIG	TEILNR/PARTNR	BEZEICHNUNG	DESCRIPTION	QTY
1	503.31.001.744	VERGASER KEIHIN PWK 39 2002 125/200 SX	CARBURETOR KEIHIN PWK 39 2002 125/200 SX	1
1	503.31.001.944	VERGASER KEIHIN PWK 38AG 2002 125/200 MXC, EXC	CARBURETOR KEIHIN PWK 38AG 02 125/200 MXC, EXC	1
2	546.31.245.000	STARTKOLBEN KPL.	STARTER PISTON CPL.	1
3	546.31.209.000	SCHWIMMER R-39 16GRAMM	FLOAT R-39 16GRAMM	1
4	546.31.211.000	SCHWIMMERGEHÄUSE	FLOAT CHAMBER	1
5	545.31.610.000	DICHTUNG SCHWIMMERGEHÄUSE	GASKET FLOAT CHAMBER	1
6	545.31.699.000	VERSCHLUSSSCHRAUBE M 18X1	PLUG M 18X1	1
7	0770 180230	O-RING 18,00X2,30 NBR 70	O-RING 18,00X2,30 NBR 70	1
8	546.31.220.000	SCHWIMMERNADEL	FLOAT NEEDLE	1
9	545.31.612.100	HALTEBLECH F. ENTLÜFTUNGSSCHL.	RETAINING PLATE FOR BLEEDER	2
10	545.31.607.035	LEERLAUFDÜSE GR.35 KEIHIN 125/200 EXC EU+AUS	IDLE JET 35 KEIHIN 125/200 EXC EU+AUS	X
10	545.31.607.038	LEERLAUFDÜSE GR.38 KEIHIN	IDLE JET 38 KEIHIN	X
10	545.31.607.040	LEERLAUFDÜSE GR.40 KEIHIN	IDLE JET 40 KEIHIN	X
10	545.31.607.042	LEERLAUFDÜSE GR.42 KEIHIN	IDLE JET 42 KEIHIN	X
10	545.31.607.045	LEERLAUFDÜSE GR.45 KEIHIN 200 MXC, EXC USA	IDLE JET 45 KEIHIN 200 MXC, EXC USA	1
10	545.31.607.048	LEERLAUFDÜSE GR.48 KEIHIN 125/200 SX	IDLE JET 48 KEIHIN 125/200 SX	1
10	545.31.607.050	LEERLAUFDÜSE GR.50 KEIHIN	IDLE JET 50 KEIHIN	X
10	545.31.607.052	LEERLAUFDÜSE GR.52 KEIHIN	IDLE JET 52 KEIHIN	X
10	545.31.607.055	LEERLAUFDÜSE GR.55 KEIHIN	IDLE JET 55 KEIHIN	X
10	545.31.607.058	LEERLAUFDÜSE GR.58 KEIHIN	IDLE JET 58 KEIHIN	X
10	545.31.607.060	LEERLAUFDÜSE GR.60 KEIHIN	IDLE JET 60 KEIHIN	X
10	545.31.607.062	LEERLAUFDÜSE GR.62 KEIHIN	IDLE JET 62 KEIHIN	X
10	545.31.607.065	LEERLAUFDÜSE GR.65 KEIHIN	IDLE JET 65 KEIHIN	X
10	545.31.607.070	LEERLAUFDÜSE GR.70 KEIHIN	IDLE JET 70 KEIHIN	X
10	545.31.607.075	LEERLAUFDÜSE GR.75 KEIHIN	IDLE JET 75 KEIHIN	X
10	545.31.607.080	LEERLAUFDÜSE GR.80 KEIHIN	IDLE JET 80 KEIHIN	X
11	545.31.636.004	DÜSENNADEL NOZ D KEIHIN	JET NEEDLE NOZ D KEIHIN	X
11	545.31.636.005	DÜSENNADEL NOZ E KEIHIN 200 MXC, EXC USA	JET NEEDLE NOZ E KEIHIN 200 MXC, EXC USA	1
11	545.31.636.006	DÜSENNADEL NOZ F KEIHIN	JET NEEDLE NOZ F KEIHIN	X
11	545.31.636.007	DÜSENNADEL NOZ G KEIHIN	JET NEEDLE NOZ G KEIHIN	X

* = NEUTEIL / NEW PART X = NACH BEDARF / AS REQUIRED

ACHTUNG !!!
Vor dem Einbau des Vergasers, Bedüsung kontrollieren.
CAUTION !!!
Before mounting the carburetor, check the jetting.



03-503.31.0

FIG	TEILNR/PARTNR	BEZEICHNUNG	DESCRIPTION	QTY
11	545.31.636.008	DÜSENNADEL NOZ H KEIHIN	JET NEEDLE NOZ H KEIHIN	X
11	545.31.636.009	DÜSENNADEL NOZ I KEIHIN	JET NEEDLE NOZ I KEIHIN	X
11	545.31.634.367	DÜSENNADEL R 1467 D KEIHIN	JET NEEDLE R 1467 D KEIHIN	X
11	545.31.634.368	DÜSENNADEL R 1468 D KEIHIN	JET NEEDLE R 1468 D KEIHIN	X
11	545.31.634.369	DÜSENNADEL R 1469 D KEIHIN 125 SX	JET NEEDLE R 1469 D KEIHIN 125 SX	1
11	545.31.634.370	DÜSENNADEL R 1470 D KEIHIN	JET NEEDLE R 1470 D KEIHIN	X
11	545.31.634.175	DÜSENNADEL R 1475 J KEIHIN 200 EXC EU+AUS	JET NEEDLE R 1475 J KEIHIN 200 EXC EU+AUS	1
11	545.31.634.272	DÜSENNADEL R 1472 N KEIHIN 125 EXC	JET NEEDLE R 1472 N KEIHIN 125 EXC	1
11*	547.31.034.200	DÜSENNADEL KEIHIN R1468G 03 200 SX	JET NEEDLE KEIHIN R1468G 03 200 SX	1
11*	547.31.034.300	DÜSENNADEL KEIHIN R1469G 03	JET NEEDLE KEIHIN R1469 03	X
12	545.31.629.000	KLEMMFEDER	CLIP FOR JET NEEDLE	1
13	546.31.235.006	GASSCHIEBER 60 KEIHIN	THROTTLE VALVE 60 KEIHIN	X
13	546.31.235.106	GASSCHIEBER 65 KEIHIN 125/200 MXC, EXC	THROTTLE VALVE 65 KEIHIN 125/200 MXC, EXC	1
13	546.31.235.055	GASSCHIEBER 55 KEIHIN 125/200 SX	THROTTLE VALVE 55 KEIHIN 125/200 SX	1
14	546.31.232.000	NIPPEL	NIPPLE	1
15	546.31.227.000	VERGASERDECKEL	CARBURETOR COVER	1
16	545.31.628.000	GUMMIDICHTRING 40X46X1	RUBBER SEAL RING 40X46X1	1
17	545.31.617.000	STELLSCHRAUBE	ADJUSTMENT SCREW	1
18	545.31.615.000	FEDER FÜR STELSCHRAUBE	SPRING FOR ADJUSTMENT SCREW	1
19	546.31.230.000	SCHIEBERFEDER	SLIDING SPRING	1
20	545.31.621.000	KLAMMER	CLAMP	1
21	0016 040163	SK.BUNDSCHRAUBE M 4X16 SW=6	HH COLLAR SCREW M 4X16 WS=6	4
22	310.07.007.101	PVC-SCHLAUCH 4X6MM	BREATHER HOSE 4X6MM	2,00
23	520.31.137.001	PVC-SCHLAUCH 3X5MM	PVC-HOSE 3X5MM	0,33
24	545.31.608.000	STIFT 2,5X25	STUD 2,5X25	1
25	545.31.696.000	KLAMMER 6 MM	CLAMP 6 MM	X
26	545.31.623.142	HAUPTDÜSE GR.142 KEIHIN	MAIN JET 142 KEIHIN	X
26	545.31.623.148	HAUPTDÜSE GR.148 KEIHIN 125 EXC	MAIN JET 148 KEIHIN 125 EXC	1
26	545.31.623.150	HAUPTDÜSE GR.150 KEIHIN	MAIN JET 150 KEIHIN	X

* = NEUTEIL / NEW PART

X = NACH BEDARF / AS REQUIRED

ACHTUNG !!!
Vor dem Einbau des Vergasers, Bedüsung kontrollieren.
CAUTION !!!
Before mounting the carburetor, check the jetting.

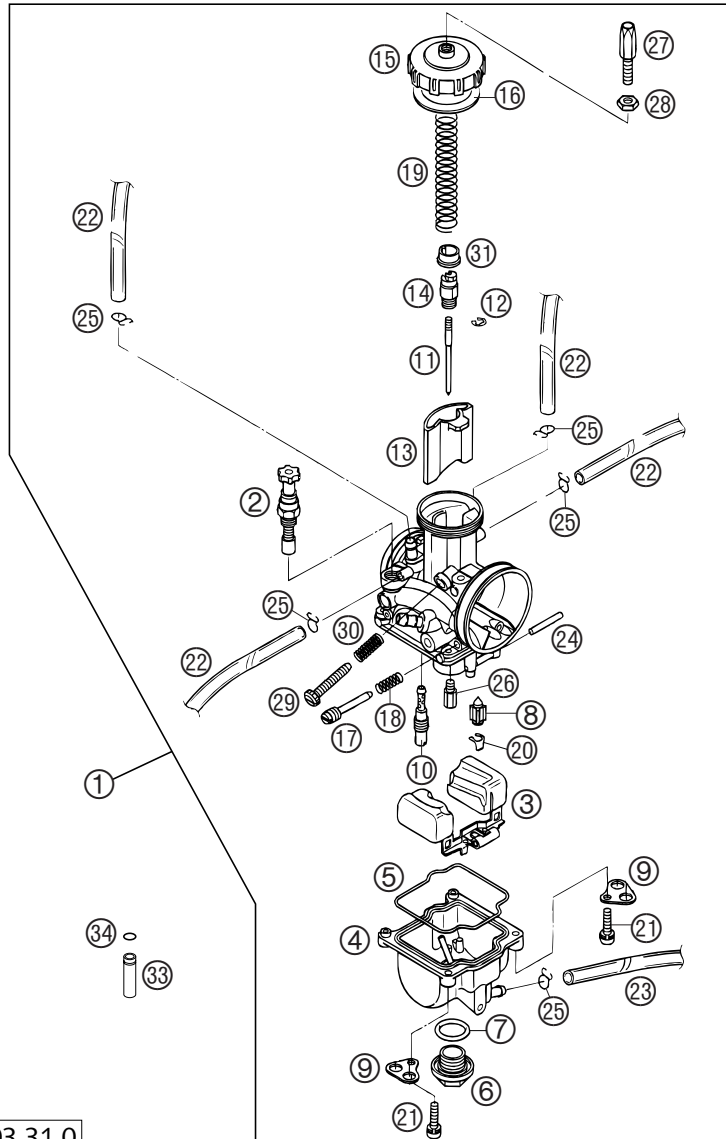

FIG	TEILNR/PARTNR	BEZEICHNUNG	DESCRIPTION	QTY
26	545.31.623.158	HAUPTDÜSE GR.158 KEIHIN	MAIN JET 158 KEIHIN	X
26	545.31.623.160	HAUPTDÜSE GR.160 KEIHIN	MAIN JET 160 KEIHIN	X
26	545.31.623.165	HAUPTDÜSE GR.165 KEIHIN	MAIN JET 165 KEIHIN	X
26	545.31.623.170	HAUPTDÜSE GR.170 KEIHIN	MAIN JET 170 KEIHIN	X
26	545.31.623.172	HAUPTDÜSE GR.172 KEIHIN	MAIN JET 172 KEIHIN	X
26	545.31.623.175	HAUPTDÜSE GR.175 KEIHIN	MAIN JET 175 KEIHIN	X
26	545.31.623.178	HAUPTDÜSE GR.178 KEIHIN 200 MXC, EXC USA	MAIN JET 178 KEIHIN 200 MXC, EXC USA	1
26	545.31.623.180	HAUPTDÜSE GR.180 KEIHIN 200 EXC EU+AUS	MAIN JET 180 KEIHIN 200 EXC EU+AUS	1
26	545.31.623.182	HAUPTDÜSE GR.182 KEIHIN	MAIN JET 182 KEIHIN	X
26	545.31.623.185	HAUPTDÜSE GR.185 KEIHIN 125 SX	MAIN JET 185 KEIHIN 125 SX	1
26	545.31.623.188	HAUPTDÜSE GR.188 KEIHIN	MAIN JET 188 KEIHIN	X
26	545.31.623.190	HAUPTDÜSE GR.190 KEIHIN 200 SX	MAIN JET 190 KEIHIN 200 SX	1
26	545.31.623.192	HAUPTDÜSE GR.192 KEIHIN	MAIN JET 192 KEIHIN	X
26	545.31.623.195	HAUPTDÜSE GR.195 KEIHIN	MAIN JET 195 KEIHIN	X
27	545.31.625.000	STELLSCHRAUBE M 6X0,75	ADJUSTMENT SCREW M 6X0,75	1
28	520.31.126.000	SK.MUTTER M 6X0,75 DIN0439	HEXAGON NUT M 6X0,75 DIN0439	1
29	546.31.219.100	STELLSCHRAUBE M 5	ADJUSTMENT SCREW M 5	1
30	546.31.118.000	FEDER	SPRING	1
31	546.31.231.000	FEDERTASSE	SPRING CAP	1
33	503.31.029.036	SCHIEBERANSCHLAG L=36MM	SLIDE STOP L=36MM	X
34	0770 060018	O-RING 6,00X1,78	O-RING 6,00X1,78	X

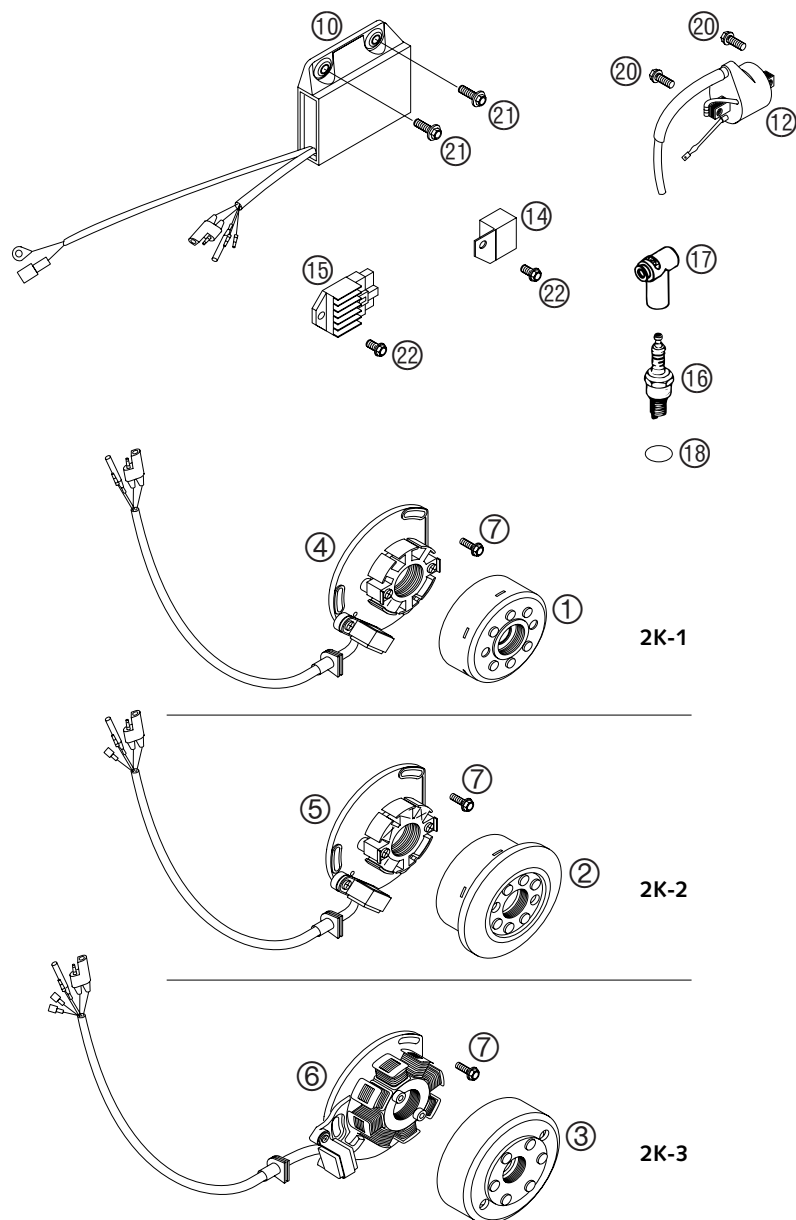

FIG	TEILNR/PARTNR	BEZEICHNUNG	DESCRIPTION	QTY
1	547.39.005.000	ROTOR KOKUSAN 2K-1/2K-4 '97 125/200 SX	FLYWHEEL KOKUSAN 2K-1/2K-4 '97 125/200 SX	1
2	547.39.005.144	ROTOR KOKUSAN 2K-2 KPL. '97 200 MXC, EXC USA	FLYWHEEL KOKUSAN 2K-2 CPL. '97 200 MXC, EXC USA	1
3	503.39.005.200	ROTOR KOKUSAN 2K-3 125/200 EXC EU+AUS	FLYWHEEL KOKUSAN 2K-3 '98 125/200 EXC EU+AUS	1
4	503.39.004.000	STATOR KOKUSAN 2K-1 125/200 SX	STATOR KOKUSAN 2K-1 '98 125/200 SX	1
5	503.39.004.100	STATOR KOKUSAN 2K-2 200 MXC, EXC USA	STATOR KOKUSAN 2K-2 '98 200 MXC, EXC USA	1
6	503.39.004.200	STATOR KOKUSAN 2K-3 125/200 EXC EU+AUS	STATOR KOKUSAN 2K-3 '98 125/200 EXC EU+AUS	1
7	0015 050163	SK.BUNDSCHRAUBE M 5X16 SW=8	HH COLLAR SCREW M 5X16 WS=8	3
10	503.39.031.400	ELEKTRONIKBOX CU7442 125 2000 125 SX, EXC	CDI UNIT CU7442 125 2000 125 SX, EXC	1
10*	523.39.031.500	ELEKTRONIKBOX 200 SX 03 200 SX	CDI UNIT 200 SX 03 200 SX	1
10	523.39.031.300	ELEKTRONIKBOX CU7434 200'99 200 MXC, EXC	CDI UNIT CU7434 200'99 200 MXC, EXC	1
12	503.39.006.000	ZÜNDSP.KOK.IG 3834 125-380 '98	IGNI.COIL KOKU.3834 125-380'98	1
14	547.11.034.000	SPANNUNGSREGLER KOKU. EXC USA 200 EXC USA	VOLTAGE REGULATOR KOKU.EXC USA 200 EXC USA	1
15	503.11.034.000	SPANNUNGSREGLER 12V 125-380'98 125/200 EXC EU+AUS	VOLTAGE REGULA. 12V 125-200'98 125/200 EXC EU+AUS	1
16	503.39.093.100	ZÜNDKERZE NGK BR 9EVX 2000 125/200 SX, 125 EXC	SPARK PLUG NGK BR 9EVX 2000 125/200 SX, 125 EXC	1
16	543.31.093.310	ZÜNDKERZE NGK BR8EG 200 MXC, EXC	SPARK PLUG NGK BR8EG 200 MXC, EXC	1
17	545.31.010.000	KERZENSTECKER LB05EMH NGK	SPARK PLUG CAP LB05EMH NGK	1
18	0770 150040	O-RING 15,00X4,00 NBR 70	O-RING 15,00X4,00 NBR 70	1
20	0015 060163	SK.BUNDSCHRAUBE M 6X16 SW=8	HH COLLAR SCREW M 6X16 WS=8	2
21	0014 060203	SK.BUNDSCHRAUBE M 6X20 SW=8	HH COLLAR SCREW M 6X20 WS=8	2
22	0015 060123	SK.BUNDSCHRAUBE M 6X12 SW=8	HH COLLAR SCREW M 6X12 WS=8	1

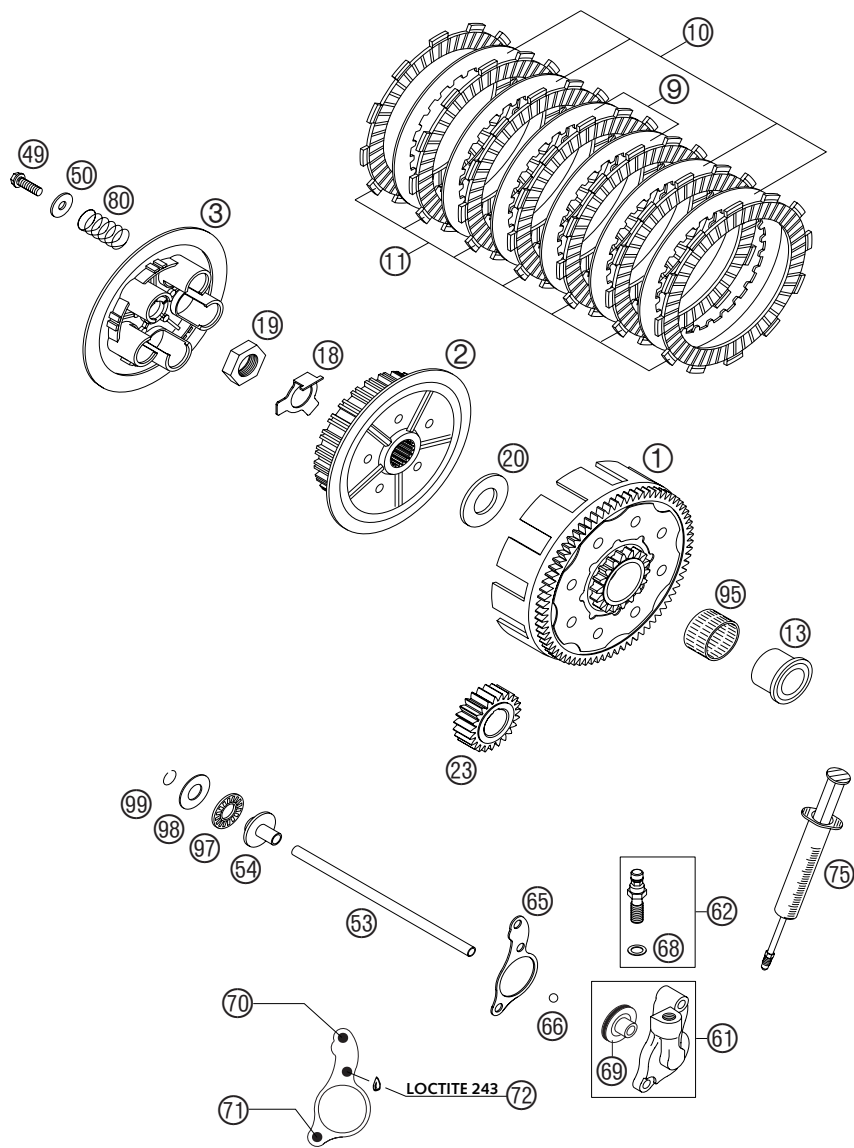
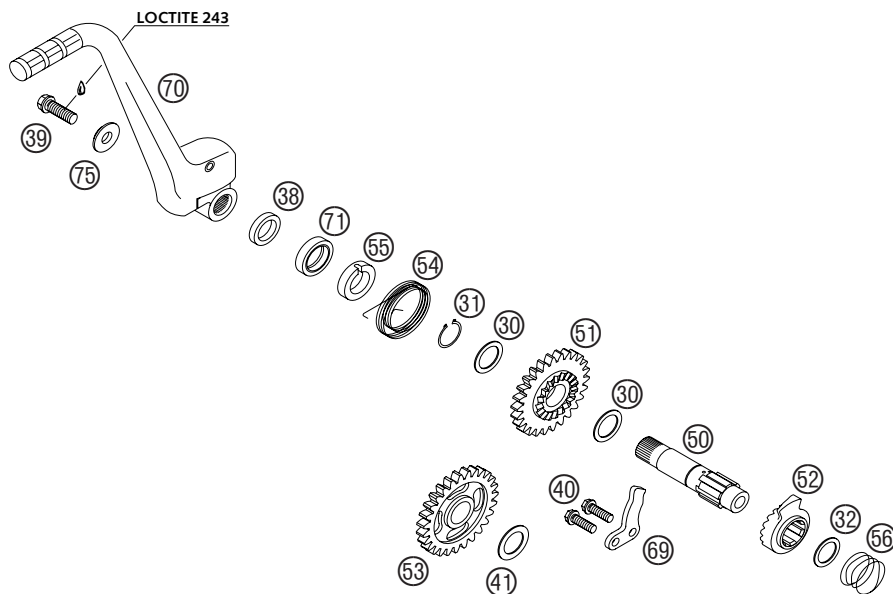

FIG	TEILNR/PARTNR	BEZEICHNUNG	DESCRIPTION	QTY
1	503.32.000.073	KUPPLUNGSKORB 73-Z 125/200 '98 OHNE PRIMÄRRITZEL	OUTER CLUTCH H.73-T 125/200'98 WITHOUT PRIMARY PINION	1
2	503.32.002.000	MITNEHMER 125/200'98	INNER CLUTCH HUB 125/200'98	1
3	503.32.003.000	DRUCKKAPPE 125/200'98	PRESSURE PLATE 125/200'98	1
9	503.32.010.100	ZWISCHENLAMELLE STAHL 1,5MM'98	INTERMEDI. DISC STEEL 1,5MM'98	2
10	503.32.010.000	ZWISCHENLAMELLE ALU 1,5MM '98	INTERMEDIATE DISC ALU 1,5MM'98	4
11	503.32.011.000	BELAGLAMELLE ORGANISCH 3MM '98	ORGANIC DISK 3MM '98	7
13	503.32.013.000	INNENRING 20X26X25,9 '98	INNER RING 20X26X34X25,9 '98	1
18	503.32.018.000	SICHERUNGSBLECH 1,5MM '98	SHEET METAL LOCK 1,5MM '98	1
19	0936 181505	SK.MUTTER DIN0936-M18X1,5 RE.	HEXAGON NUT DIN0936-M18X1,5 R.	1
20	503.32.020.000	ANLAUFSCHLEIBE 20X39,6X3 '98	STOP DISK 20X39,6X3 '98	1
23	503.32.023.023	PRIMÄRRITZEL 23-Z 125/200'98	PRIMARY PINION 23-T 125/200'98	1
49	0015 060203	SK.BUNDSCHRAUBE M 6X20 SW=8	HH COLLAR SCREW M 6X20 WS=8	5
50	502.32.050.000	STAHSCHLEIBE 6,2X18X2	WASHER 6,2X18X2	5
53	503.32.017.200	DRUCKSTANGE L=179MM 125/200'98	PUSH ROD L=179MM 125/200'98	1
54	503.32.054.051	DRUCKPILZ 125-380 '98	PRESSURE PIECE 125-380 '98	1
61	503.32.061.044	NEHMERZYLINDER KPL. 125/200'98	CYLINDER CPL. 125/200'98	1
62	503.32.062.000	HOHLSCHRAUBE KPL. M 10X1 '98	HOLLOW SCREW CPL. M 10X1 '98	1
65	503.32.065.051	KUPPLUNGS-AUSRÜCKDICHT. 0,3MM	CLUTCH RELEASE GASKET 0,3MM	X
65	503.32.065.052	KUPPLUNGS-AUSRÜCKDICHT. 0,5MM	CLUTCH RELEASE GASKET 0,5MM	X
65	503.32.065.053	KUPPLUNGS-AUSRÜCKDICHT. 0,75MM	CLUTCH RELEASE GASKET 0,75MM	X
66	0401 070003	KUGEL DIN5401-7	BALL DIN5401-7	1
68	420.13.226.000	CU-DICHRING DIN7603-10X16X1	CU-SEAL RING DIN7603-10X16X1	1
69	503.32.066.000	KOLBEN MIT O-RING 125/200 2000	PISTON W. O-RING 125/200 2000	1
70	0015 060403	SK.BUNDSCHRAUBE M 6X40 SW=8	HH COLLAR SCREW M 6X40 WS=8	1
71	0015 060203	SK.BUNDSCHRAUBE M 6X20 SW=8	HH COLLAR SCREW M 6X20 WS=8	1
72	0015 060253	SK.BUNDSCHRAUBE M 6X25 SW=8	HH COLLAR SCREW M 6X25 WS=8	1
75	503.29.050.000	ENTLÜFT.SPRITZE HYDR. KUPPLUNG	VENT INJEKTION HYDR. CLUTCH	1
80	503.32.005.000	KUPPLUNGSFEDER 2,3X39,5 125'98	CLUTCH SPRING 2,3X39,5 125'98	5
80	523.32.005.000	KUPPLUNGSFEDER 2,4X40 200'98	CLUTCH SPRING 2,4X40 200'98	5
95	565.32.095.000	NADELKRANZ K 26X30X22 ZW.KSE	NEEDLE BEARING K26X30X22ZW.KSE	1
97	546.37.097.200	AXIALLAGER AXK 1226	AXIAL NEEDLE BEARING AXK 1226	1
98	546.37.098.200	AXIALSCHEIBE AS1226 12X26X1	AXIAL WASHER AS1226 12X26X1	1
98	546.37.098.300	AXIALSCHEIBE 12,5X25,8X1,5	AXIAL WASHER 12,5X25,8X1,5	X
99	0993 012000	SPRENGRING DIN7993-RW12	CIRCLIP DIN7993-RW12	1

FIG	TEILNR/PARTNR	BEZEICHNUNG	DESCRIPTION	QTY
30	503.33.030.000	ANLAUFSCHIEBE 17,2X24X1	STOP DISK 17,2X24X1	2
31	0471 170010	SICHERUNGSRING DIN0471-17X1	CIRCLIP DIN0471-17X1	1
32	0988 162210	PASSCHIEBE DIN0988-16X22X1	THRUST WASHER DIN0988-16X22X1	1
38	503.33.038.100	DISTANZHÜLSE 16X23X26X6,1	SPACER BUSHING 16X23X26X6,1	1
39	0015 080203	SK.BUNDSCHRAUBE M 8X20 SW=10	HH COLLAR SCREW M 8X20 WS=10	1
40	0015 060163	SK.BUNDSCHRAUBE M 6X16 SW=8	HH COLLAR SCREW M 6X16 WS=8	2
41	503.33.041.000	ANLAUFSCHIEBE 17,2X26X1 B	STOP DISC 17,2X26X1 B	1
50	503.33.050.000	KICKSTARTERWELLE 125/200'98	KICKSTARTER SHAFT 125/200'98	1
51	503.33.051.026	STARTERRAD 26-Z 125/200'98	KICKSTART.GEAR 26-T 125/200'98	1
52	503.33.052.000	KICKSTARTERSPERRAD	KICKSTARTER RATCHET	1
53	503.33.053.027	STARTERZWISCHENRAD 27-Z	INTERMEDIATE GEAR 27-T '98	1
54	503.33.054.000	KICKSTARTERFEDER 2,6MM '98	KICKSTARTER SPRING 2,6MM '98	1
55	503.33.055.000	MITNEHMERNABE 125/200'98	DRIVING HUB 125/200'98	1
56	503.33.056.000	SPERRADFEDER 1,4MM '98	SPRING 1,4MM '98	1
69	503.33.069.000	ANSCHLAGBLECH 4MM 125/200'98	STOP MET.SHEET 4MM 125/200'98	1
70	503.33.070.044	KICKSTARTER KPL. 125/200'98	KICKSTARTER CPL. 125/200'98	1
71	0760 172870	WELLENDICHTRING 17X28X7 B	SHAFT SEAL RING 17X28X7 B	1
75	503.33.075.000	FASONSCHIEBE 8,2X22X4,5 '98	WASHER 8,2X22X4,5 '98	1



ACHTUNG !
Bei Bestellung von Getrieberädern, Markierung beachten.

CAUTION !
When you order transmission gears, check marking.

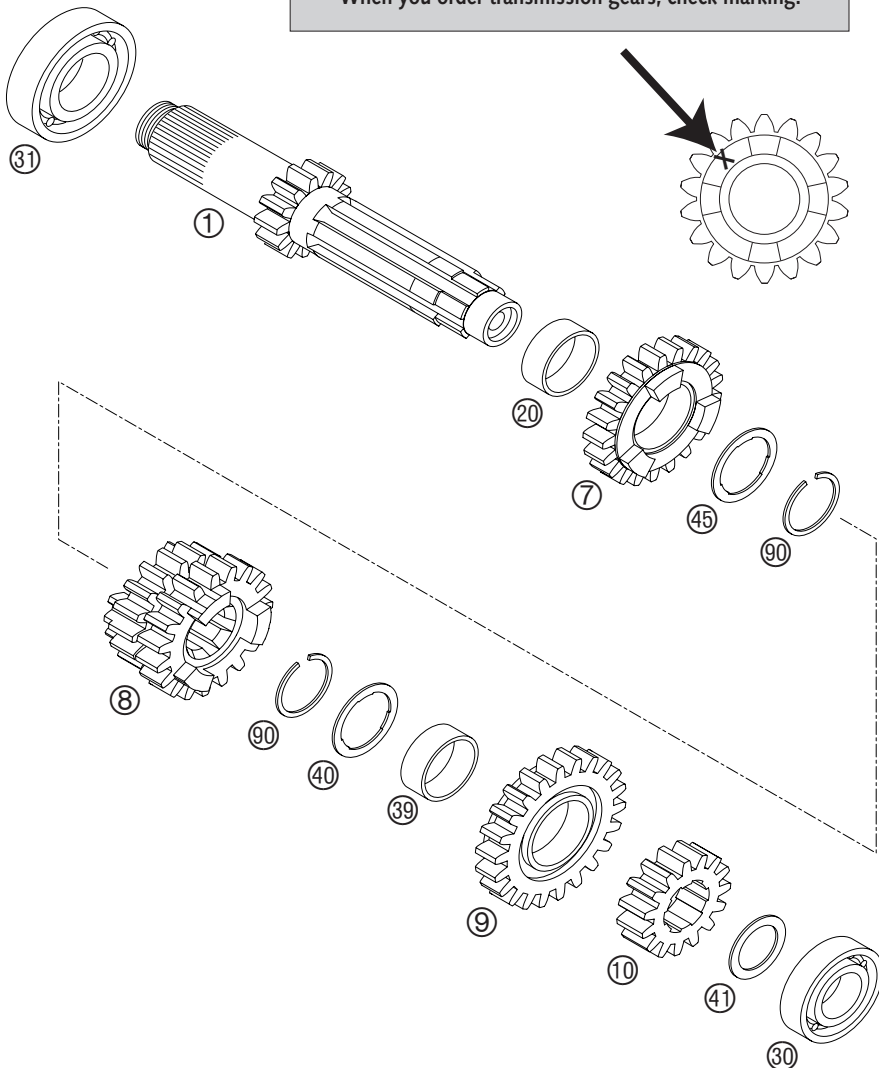

FIG	TEILNR/PARTNR	BEZEICHNUNG	DESCRIPTION	QTY
1	503.33.001.044	ANTRIEBSWELLE KPL. 13-Z '98	MAIN SHAFT CPL. 13-T '98	1
7	503.33.007.000	LOSRAD 5.GANG 21-Z „5S21“ '98	IDLER G.5TH G.21-T „5S21“ '98	1
8	503.33.008.000	SCHIEBERAD 3/4.GANG 17/19-Z'98 „3S17“ - „4S19“	SLIDING GEAR 3/4.GEAR 17/19-T „3S17“ - „4S19“	1
9	503.33.009.000	LOSRAD 6.GANG 22-Z „6S22“ '98 NUR FÜR 200 SX, MXC	IDLER G.6TH G.22-T „6S22“ '98 ONLY FOR 200 SX, MXC	1
10*	503.33.010.100	FESTRAD 2.GANG 15-Z „2S15“ 03	SOLID GEAR 2ND G.15-T“2S15“ 03	1
20	503.33.020.000	LOSRADBÜCHSE 22X25X11,1 A	IDLER GEAR BUSH. 22X25X11,1 A	1
30*	0625 160030	RILLENKUGELLAGER 16003 C3	GROOVED BALL BEARING 16003 C3	1
31	0625 060042	RILLENKUGELLAGER 6004 TN9 C4	BALL BEARING 6004 TN9 C4	1
39	503.33.020.000	LOSRADBÜCHSE 22X25X11,1 A NUR FÜR 200 SX, MXC	IDLER GEAR BUSH. 22X25X11,1 A ONLY FOR 200 SX, MXC	1
40	503.33.040.000	ANLAUFSCHIEBE 22,2X27,8X1 A NUR FÜR 200 SX, MXC	STOP DISC 22,2X27,8X1 A ONLY FOR 200 SX, MXC	1
41	503.33.041.000	ANLAUFSCHIEBE 17,2X26X1 B	STOP DISC 17,2X26X1 B	1
45	503.33.045.000	ANLAUFSCHIEBE 22,2X27,8X1	STOP DISK 22,2X27,8X1	1
90	501.33.090.000	SPRENGRING 22X1,2	LOCK RING 22X1,2	2

ACHTUNG !
Bei Bestellung von Getrieberädern, Markierung beachten.

CAUTION !
When you order transmission gears, check marking.

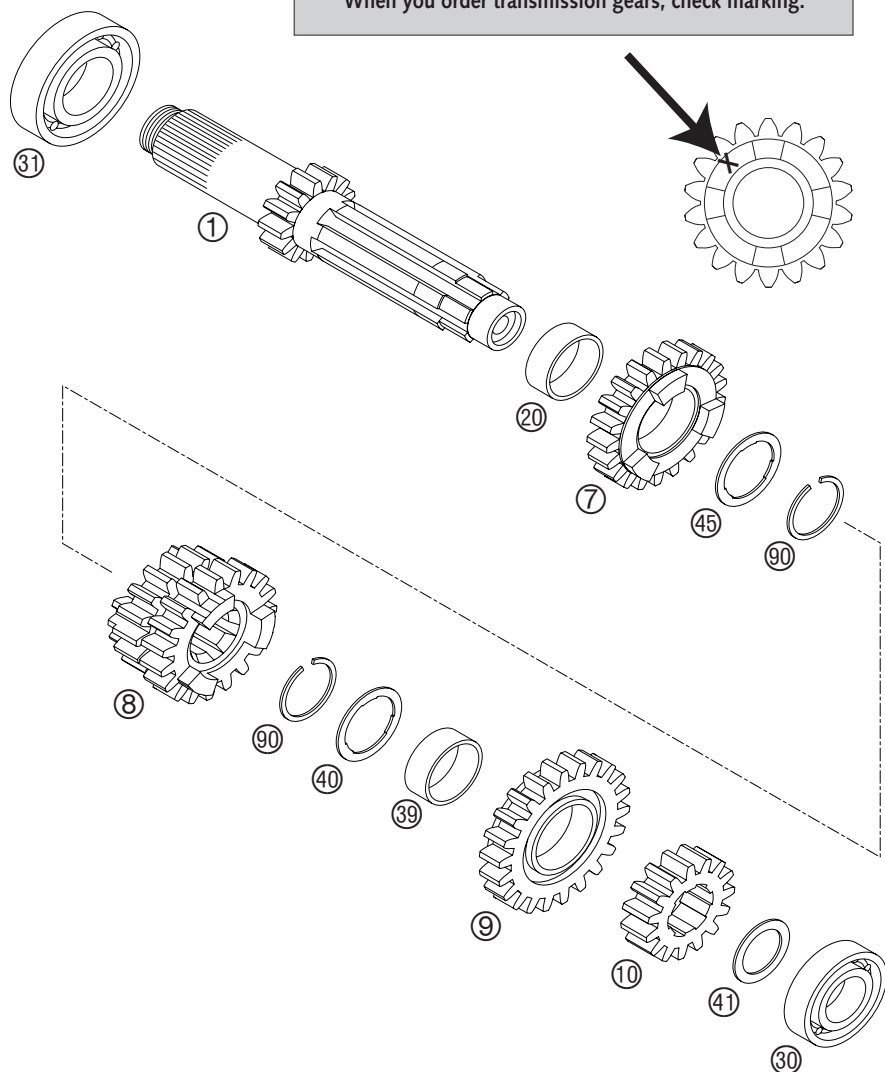
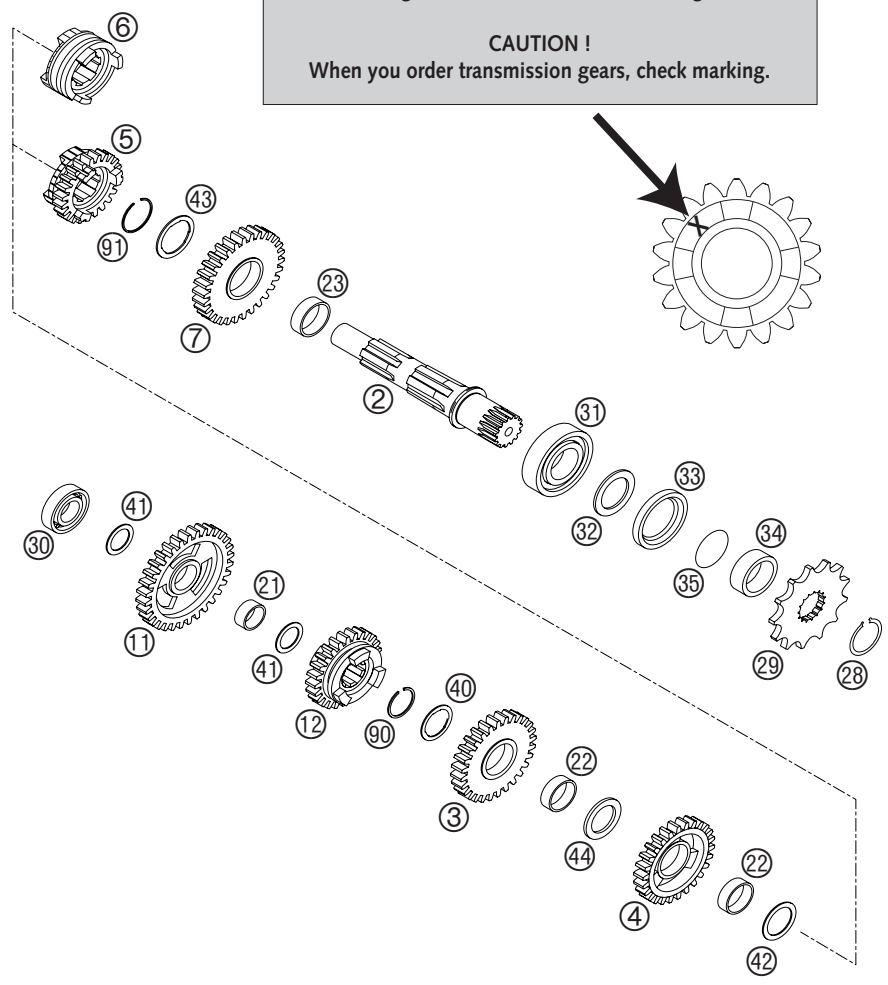

FIG	TEILNR/PARTNR	BEZEICHNUNG	DESCRIPTION	QTY
1	503.33.001.144	ANTRIEBSWELLE KPL. 12-Z '98	MAIN SHAFT CPL. 12-T '98	1
7	503.33.007.000	LOSRAD 5.GANG 21-Z „5S21“ '98 125 EXC	IDLER G.5TH G.21-T „5S21“ '98 125 EXC	1
7	523.33.007.000	LOSRAD 5.GANG 17-Z „5G17“ '99 200 EXC	IDLER G.5TH G.17-T „5G17“ '99 200 EXC	1
8	503.33.008.000	SCHIEBERAD 3/4.GANG 17/19-Z'98 „3S17“ - „4S19“	SLIDING GEAR 3/4.GEAR 17/19-T „3S17“ - „4S19“	1
9	503.33.009.100	LOSRAD 6.GANG 20-Z „6G20“ '98 125 EXC	IDLER G.6TH G.20-T „6G20“ '98 125 EXC	1
9	503.33.009.300	LOSRAD 6.GANG 22-Z „6G22“ '98 200 EXC	IDLER G.6TH G.22-T „6G22“ '98 200 EXC	1
10*	503.33.010.100	FESTRAD 2.GANG 15-Z „2S15“ '03	SOLID GEAR 2ND G.15-T"2S15" '03	1
20	503.33.020.000	LOSRADBÜCHSE 22X25X11,1 A	IDLER GEAR BUSH. 22X25X11,1 A	1
30*	0625 160030	RILLENKUGELLAGER 16003 C3	GROOVED BALL BEARING 16003 C3	1
31	0625 060042	RILLENKUGELLAGER 6004 TN9 C4	BALL BEARING 6004 TN9 C4	1
39	503.33.020.000	LOSRADBÜCHSE 22X25X11,1 A	IDLER GEAR BUSH. 22X25X11,1 A	1
40	503.33.040.000	ANLAUFSCHEIBE 22,2X27,8X1 A	STOP DISC 22,2X27,8X1 A	1
41	503.33.041.000	ANLAUFSCHEIBE 17,2X26X1 B	STOP DISC 17,2X26X1 B	1
45	503.33.045.000	ANLAUFSCHEIBE 22,2X27,8X1	STOP DISK 22,2X27,8X1	1
90	501.33.090.000	SPRENGRING 22X1,2	LOCK RING 22X1,2	2

FIG	TEILNR/PARTNR	BEZEICHNUNG	DESCRIPTION	QTY
2	503.33.002.000	ABTRIEBSWELLE 125/200 '98	COUNTER SHAFT 125/200 '98	1
3	503.33.003.000	LOSRAD 3.GANG 28-Z „3S28“ '98	IDLE G.3RD G.28-T „3S28“ '98	1
4	503.33.004.000	LOSRAD 4.GANG 26-Z „4S26“ '98	IDLE G.4TH G.26-T „4S26“ '98	1
5	503.33.005.200	SCHIEBER.6.GANG 23-Z „6S23“'98 200 SX, MXC	SLIDING G.6TH G.23-T „6S23“'98 200 SX, MXC	1
6*	503.33.005.400	SCHIEBERAD 6.GANG SX 2003 125 SX	SLIDING GEAR 6TH GEAR SX 2003 125 SX	1
7	503.33.006.000	LOSRAD 2.GANG 30-Z „2S30“ '98	IDLER G. 2ND G. 30-T „2S30“'98	1
11	503.33.011.000	LOSRAD 1.GANG 32-Z „1S32“ '98	IDLER G. 1ST G. 32-T „1S32“'98	1
12	503.33.012.000	SCHIEBER.5.GANG 25-Z „5S25“'98	SLIDING G.5TH G.25-T „5S25“'98	1
21	503.33.021.000	LOSRADBÜCHSE 17X20X9,7 B	IDLER GEAR BUSHING 17X20X9,7 B	1
22	503.33.022.000	LOSRADBÜCHSE 22X25X8,1 C	IDLER GEAR BUSHING 22X25X8,1 C	2
23	503.33.023.000	LOSRADBÜCHSE 25X28X9,7 D	IDLER GEAR BUSHING 25X28X9,7 D	1
28	520.33.096.000	SICH.RING DIN0471-25X1,64SD	LOCK RING DIN0471-25X1,64SD	1
29	500.33.029.013	KETTENRAD 13-Z	SPROCKET 13-T	1
29	500.33.029.014	KETTENRAD 14-Z	SPROCKET 14-T	1
29	500.33.029.015	KETTENRAD 15-Z	SPROCKET 15-T	X
30*	0625 060032	RILLENKUGELLAGER 6003 TN9 C4	BALL BEARING 6003 TN9 C4	1
31	0625 062058	RILLENKUGELLAGER 6205 TN9 C3	BALL BEARING 6205 TN9 C3	1
32	560.33.020.000	ANLAUFRING	STOP RING	1
33	0760 324565	WELLENDICHRING 32X45X6,5 BTSL	SHAFT SEAL RING 32X45X6,5 BTSL	1
34	546.33.014.100	DISTANZBÜCHSE 12MM	SPACER BUSHING 12MM	1
35	0770 230020	O-RING 23,00X2,00 NBR70	O-RING 23,00X2,00 NBR70	1
40	503.33.040.000	ANLAUFSCHIEBE 22,2X27,8X1 A	STOP DISC 22,2X27,8X1 A	1
41	503.33.041.000	ANLAUFSCHIEBE 17,2X26X1 B	STOP DISC 17,2X26X1 B	2
42	503.33.042.000	ANLAUFSCHIEBE 22,2X28X1 C	STOP DISK 22,2X28X1 C	1
43	503.33.043.000	ANLAUFSCHIEBE 25,2X32X1	STOP DISC 25,2X32X1	1
44	503.33.044.000	ANLAUFSCHIEBE 22,2X30X2,5	STOP DISC 22,2X30X2,5	1
90	501.33.090.000	SPRENGRING 22X1,2	LOCK RING 22X1,2	1
91	520.33.090.100	SPRENGRING 25X1,2	LOCK RING 25X1,2	1

ACHTUNG !
Bei Bestellung von Getrieberädern, Markierung beachten.

CAUTION !
When you order transmission gears, check marking.



ACHTUNG !
Bei Bestellung von Getrieberädern, Markierung beachten.

CAUTION !
When you order transmission gears, check marking.

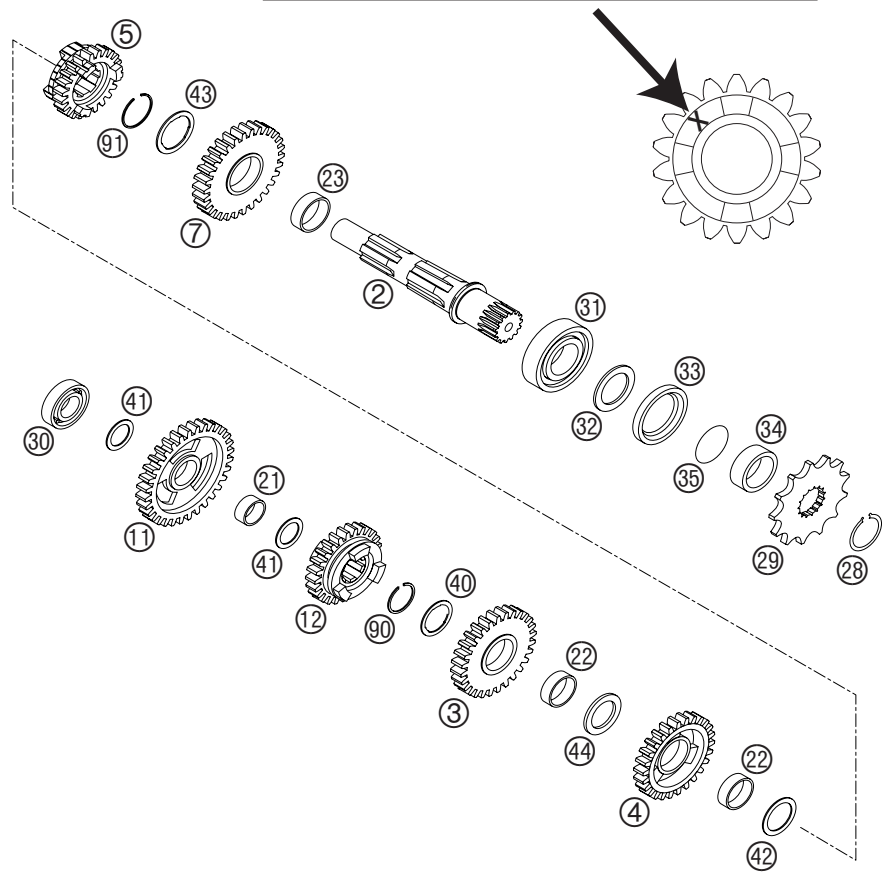

FIG	TEILNR/PARTNR	BEZEICHNUNG	DESCRIPTION	QTY
2	503.33.002.000	ABTRIEBSWELLE 125/200 '98	COUNTER SHAFT 125/200 '98	1
3	503.33.003.000	LOSRAD 3.GANG 28-Z „3S28“ '98	IDLE G.3RD G.28-T „3S28“ '98	1
4	503.33.004.000	LOSRAD 4.GANG 26-Z „4S26“ '98	IDLE G.4TH G.26-T „4S26“ '98	1
5	503.33.005.100	SCHIEBER.6.GANG 20-Z „6G20“'98 125 EXC	SLIDING G.6TH G.20-T „6G20“'98 125 EXC	1
5	503.33.005.300	SCHIEBER.6.GANG 20-Z „6E20“'98 200 EXC	SLIDING G.6TH G.20-T „6E20“'98 200 EXC	1
7	503.33.006.100	LOSRAD 2.GANG 31-Z „2G31“ '98	IDLER G. 2ND G. 31-T „2G31“'98	1
11	503.33.011.300	LOSRAD 1.GANG 33-Z „1G33“ '98	IDLER G. 1ST G. 33-T „1G33“'98	1
12	503.33.012.000	SCHIEBER.5.GANG 25-Z „5S25“'98 125 EXC	SLIDING G.5TH G.25-T „5S25“'98 125 EXC	1
12	523.33.012.000	SCHIEBER.5.GANG 19-Z „5G19“'99 200 EXC	SLIDING G.5TH G.19-T „5G19“'99 200 EXC	1
21	503.33.021.000	LOSRADBÜCHSE 17X20X9,7 B	IDLER GEAR BUSHING 17X20X9,7 B	1
22	503.33.022.000	LOSRADBÜCHSE 22X25X8,1 C	IDLER GEAR BUSHING 22X25X8,1 C	2
23	503.33.023.000	LOSRADBÜCHSE 25X28X9,7 D	IDLER GEAR BUSHING 25X28X9,7 D	1
28	520.33.096.000	SICH.RING DIN0471-25X1,64SD	LOCK RING DIN0471-25X1,64SD	1
29	500.33.029.013	KETTENRAD 13-Z	SPROCKET 13-T	X
29	500.33.029.014	KETTENRAD 14-Z	SPROCKET 14-T	1
29	500.33.029.015	KETTENRAD 15-Z	SPROCKET 15-T	X
30*	0625 060032	RILLENKUGELLAGER 6003 TN9 C4	BALL BEARING 6003 TN9 C4	1
31	0625 062058	RILLENKUGELLAGER 6205 TN9 C3	BALL BEARING 6205 TN9 C3	1
32	560.33.020.000	ANLAUFRING	STOP RING	1
33	0760 324565	WELLENDICHTRING 32X45X6,5 BTSL	SHAFT SEAL RING 32X45X6,5 BTSL	1
34	546.33.014.100	DISTANZBÜCHSE 12MM	SPACER BUSHING 12MM	1
35	0770 230020	O-RING 23,00X2,00 NBR70	O-RING 23,00X2,00 NBR70	1
40	503.33.040.000	ANLAUFSCHIEBE 22,2X27,8X1 A	STOP DISC 22,2X27,8X1 A	1
41	503.33.041.000	ANLAUFSCHIEBE 17,2X26X1 B	STOP DISC 17,2X26X1 B	2
42	503.33.042.000	ANLAUFSCHIEBE 22,2X28X1 C	STOP DISK 22,2X28X1 C	1
43	503.33.043.000	ANLAUFSCHIEBE 25,2X32X1	STOP DISC 25,2X32X1	1
44	503.33.044.000	ANLAUFSCHIEBE 22,2X30X2,5	STOP DISC 22,2X30X2,5	1
90	501.33.090.000	SPRENGRING 22X1,2	LOCK RING 22X1,2	1
91	520.33.090.100	SPRENGRING 25X1,2	LOCK RING 25X1,2	1

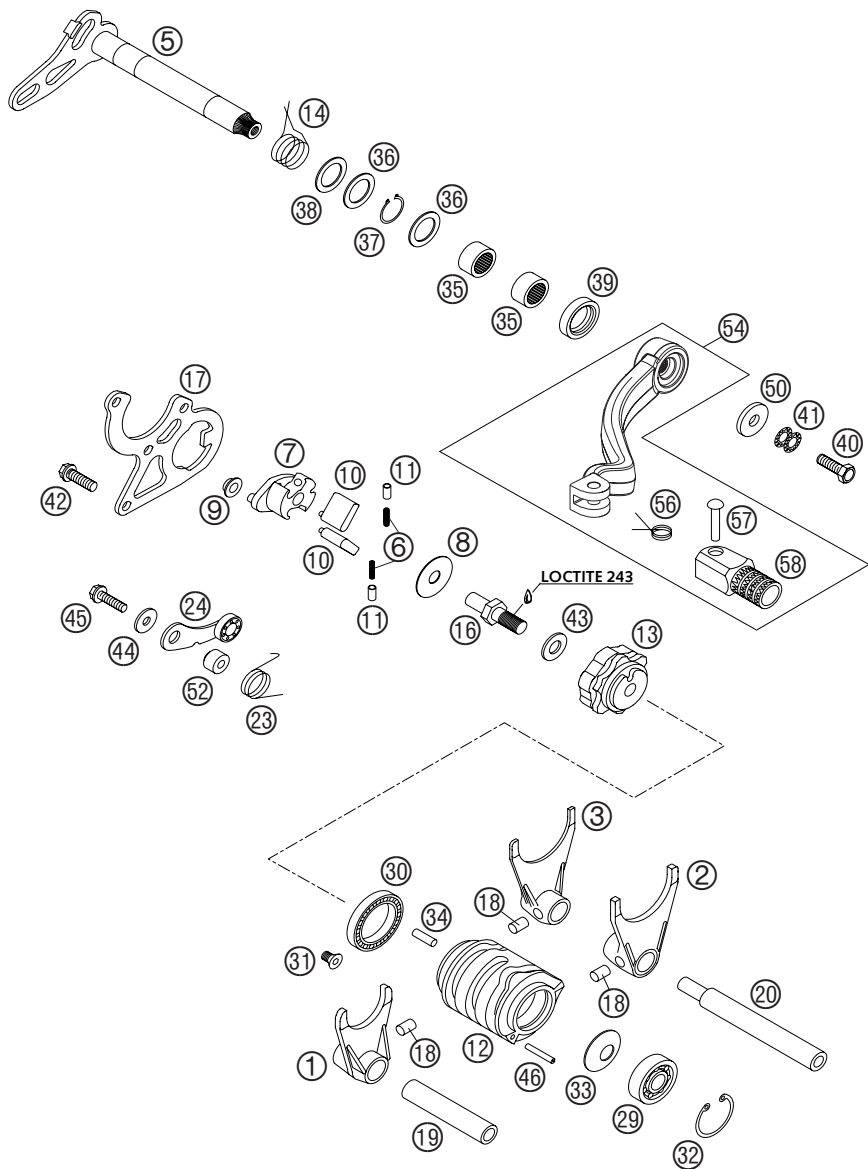
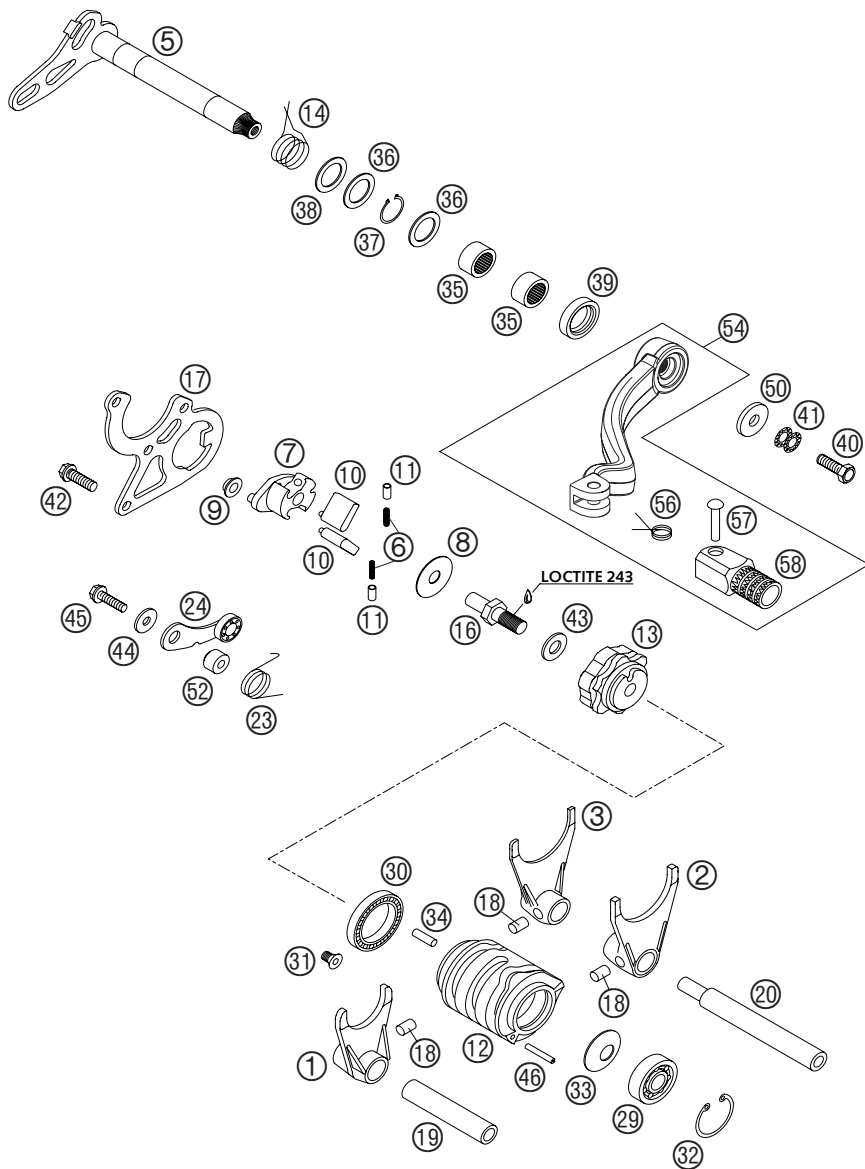

FIG	TEILNR/PARTNR	BEZEICHNUNG	DESCRIPTION	QTY
1*	503.34.001.100	SCHALTGABEL 5./6. GANG	SHIFTING FORK 5TH/6TH GEAR	03 1
2*	503.34.002.100	SCHALTGABEL 2./4. GANG	SHIFTING FORK 2ND/4TH GEAR	03 1
3*	503.34.003.100	SCHALTGABEL 1./3. GANG	SHIFTING FORK 1ST/3RD GEAR	03 1
5	503.34.005.000	SCHALTWELLE 125/200'98	SHIFTING SHAFT 125/200'98	1
6	503.34.007.052	FEDER FÜR KLINKE 0,5X11,5	SPRING FOR RATCHET 0,5X11,5	2
7	503.34.007.000	KLINKENTRÄGER 125/200'98	RATCHET SUPPORT 125/200'98	1
8	503.34.007.054	ANLAUFSCHEIBE 8,2X26X0,7	STOP DISK 8,2X26X0,7	1
9	503.34.007.053	GLEITBÜCHSE 6X8X12X4,5	BUSHING 6X8X12X4,5	1
10	503.34.007.050	SCHALTKLINKE 125/200'98	SHIFTING RATCHET 125/200'98	2
11	503.34.007.051	DRUCKPILZ 4,1X5,6X8,4 '98	PRESSURE END PAD 4,1X5,6X8,4	'98 2
12*	503.34.012.200	SCHALTWALZE ALU 125/200	SHIFTING DRUM ALU 125/200	03 1
13	503.34.013.000	ARRETIERTROMMEL 125/200'98	LOCATING DRUM 125/200'98	1
14	503.34.014.000	RÜCKHOLFEDER 3MM	RETURN SPRING 3MM	1
16	503.34.016.000	SONDERSCHRAUBE M8X21,5 SW=12	SPECIAL SCREW M8X21,5 WS=12	1
17	503.34.017.000	SCHALTKULISSE 3MM 125/200 '98	SHIFTING GATE 3MM 125/200'98	1
18*	0402 061000	NADELROLLE ZRB 6X10	NEEDLE ROLLER ZRB 6X10	3
19	503.34.019.000	SCHALTSCHIENE ANTR. 11,8X67,5	SHIFTING ROD DRIVE 11,8X67,5	1
20	503.34.020.000	SCHALTSCHIENE ABTR. 11,8X94,5	SHIFT. ROD DRIVE END 11,8X94,5	1
23	503.34.023.000	ARRETIERHEBELFEDER 2,5MM '98	LOCATING LEVER SPRING 2,5MM'98	1
24	503.34.024.044	ARRETIERHEBEL KPL. 125/200 98	LOCATING LEVER CPL. 125/200'98	1
29	0625 060006	RILLENKUGELLAGER 6000 RS1 C3	BALL BEARING 6000 RS1 C3	1
30	0625 618050	RILLENKUGELLAGER 61805 C3	BALL BEARING 61805 C3	1
31	0991 050102	SENKSCHR. DIN7991 M5X10 10.9	FLAT HEAD SCREW DIN7991-M 5X10	1
32	0472 260120	SICHERUNGSRING DIN0472-26X1,2	LOCK RING DIN0472-26X1,2	1
33	0093 251209	TELLERFEDER 12,2X25X0,9	SPRING WASHER 12,2X25X0,9	1
34	0402 040980	NADELROLLE DIN5402 NRB 4X9,8	NEEDLE ROL. DIN5402 NRB 4X9,8	1
35	546.32.095.000	NADELHÜLSE HK 1412 14,6X20X12	NEEDLE BEAR. HK 1412 14,6X20X12	2
36	490.33.031.000	ANLAUFSCHEIBE 14,3X20X1	STOP DISK 14,3X20X1	2
37	0471 140100	SICHERUNGSRING DIN0471-14X1	LOCK WASHER DIN0471-14X1	1
38	490.33.031.015	ANLAUFSCHEIBE 14,2X22X1,5	STOP DISK 14,2X22X1,5	1
39	0760 142460	WELLENDICHRING 14X24X6 B	SHAFT SEAL RING 14X24X6 B	1
40	0933 060165	SK.SCHRAUBE DIN 933 M6X16 10.9	HH SCREW DIN0933-M 6X16 10.9	1
41	502.33.041.000	NORDLOCK SCHEIBEN M 6 (PAAR)	PAIR OF WASHERS M 6 NORDLOCK	1
42	0015 060163	SK.BUNDSCHRAUBE M 6X16 SW=8	HH COLLAR SCREW M 6X16 WS=8	3
43	0125 080003	UNTERLEGSCHIEBE DIN 125 A 8,4	WASHER DIN0125-A 8,4	1
44	0125 050003	UNTERLEGSCHIEBE DIN 125 A 5,3	WASHER DIN0125-A 5,3	1

* = NEUTEIL / NEW PART X = NACH BEDARF / AS REQUIRED

FIG	TEILNR/PARTNR	BEZEICHNUNG	DESCRIPTION	QTY
45	0015 050203	SK.BUNDSCHRAUBE M 5X20 SW=8	HH COLLAR SCREW M 5X20 WS=8	1
46*	0481 030220	SPANNSTIFT DIN1481 3X22 NUR FÜR 125 SX	TENSION PIN DIN1481 3X22 ONLY FOR 125 SX	1
50	502.32.050.001	STAHLSCHEIBE 6,4X17X3	STEEL WASHER 6,4X17X3	1
52	546.34.052.300	HÜLSE FÜR ARRETIERHEBEL	SLEEVE FOR LOCKING LEVER	1
54	547.34.031.000	SCHALTHEBEL KPL. 2-TAKT 2001	SHIFT LEVER CPL. 2-STROKE 2001	1
56	546.34.032.100	SCHALTHEBELFEDER 250	SHIFTING LEVER SPRING 250	1
57	546.34.031.050	BOLZEN 6X25 FÜR SCHALTHEBEL	BOLT 6X25 FOR SHIFT LEVER	1
58	546.34.131.000	AUFTRITT FÜR SCHALTHEBEL 250	STEP PLATE FOR SHIFT LEVER 250	1



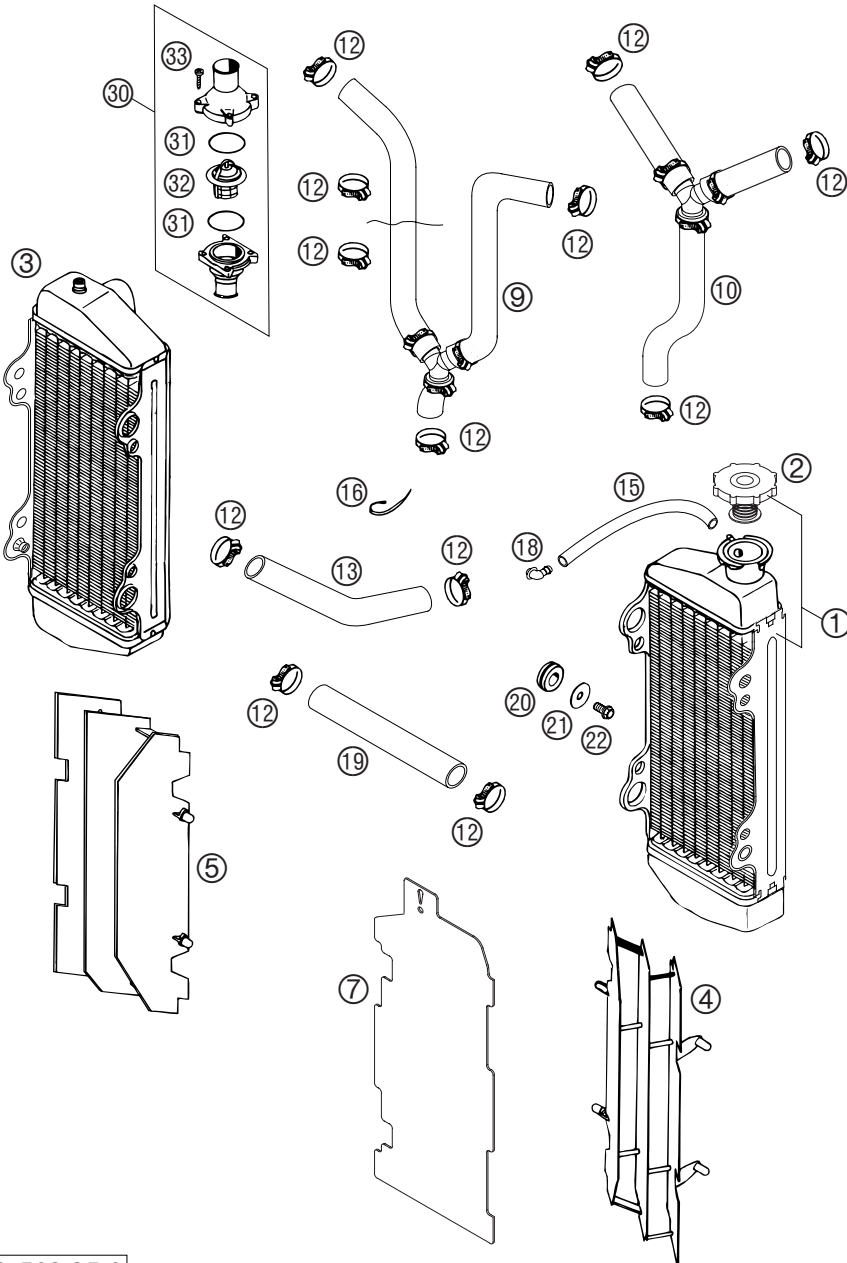

FIG	TEILNR/PARTNR	BEZEICHNUNG	DESCRIPTION	QTY
1	503.35.007.000	KÜHLER LINKS NATUR (45286) '98	RADIATOR L/S NATURE (45286)'98	1
2*	590.35.009.000	KÜHLERVERSCHLUSS 1,4 BAR 2003	RADIAT.CAP 19,6PSI (1,4BAR) 03	1
3	503.35.008.000	KÜHLER RECHTS NATUR (45285)'98	RADIATOR R/S NATURE (45285)'98	1
4	546.35.034.200	KÜHLERSCHUTZ LINKS FARBLOS '95	RADIATOR PROTECT.L/S COUL. '95	1
5	546.35.134.200	KÜHLERSCHUTZ RECHTS FARBLOS'95	RADIATOR PROTECT.R/S COUL. '95	1
7	503.35.033.000	ABDECKUNG F.KÜHLER LI. SCHWARZ FÜR WINTERBETRIEB	COVER FOR RADIATOR L/S BLACK FOR WINTER OPERATION	1
9	503.35.026.000	KÜHLERSCHLAUCH KPL. 125-380'98 125/200 MXC, EXC USA+AUS	RADIATOR HOSE CPL. 125-380'98 125/200 MXC, EXC USA+AUS	1
10*	503.35.026.200	KÜHLERSCHLAUCH INKL. Y-STÜCK03 125/200 SX	RADIATOR HOSE INCL. Y-PART 03 125/200 SX	1
12	100.01.020.000	SCHLAUCHKLEMME GEMI 16-27	HOSE CLAMP GEMI 16-27	X
13	503.35.027.000	FORMSCHLAUCH 18X25 125/200'98 WASSERPUMPE - KÜHLER	RADIATOR HOSE 18X25 125/200'98 WATER PUMP - RADIATOR	1
15	550.07.016.001	SCHLAUCH 7X10 PER METER	PVC-HOSE 7X10 PER METRE	0,2
16	440.11.076.200	KABELBAND 200MM	CABLE TIE 200MM	X
18	503.03.089.000	WINKELSTÜCK '97	ANGEL PIECE '97	1
19	565.35.025.001	KÜHLERSCHLAUCH 18X25 PER MET. KÜHLER - KÜHLER	RADIATOR HOSE 18X25 PER METRE RADIATOR - RADIATOR	0,175
20	410.01.052.000	KABELTÜLLE D=12MM	RUBBER SLEEVE D=12MM	4
21	0021 060003	SCHEIBE DIN 9021 A 6,4	WASHER DIN9021-A 6,4	4
22	0015 060123	SK.BUNDSCHRAUBE M 6X12 SW=8	HH COLLAR SCREW M 6X12 WS=8	4
30	546.35.013.144	THERMOSTATGEH. KPL. 55GRAD '98 125/200 MXC, EXC USA+AUS	THERMOSTATCASE CPL. 55DEG. '98 125/200 MXC, EXC USA+AUS	1
31	0770 320020	O-RING 32,00X2,00	O-RING 32,00X2,00	2
32	546.35.017.000	THERMOSTAT 55 GRAD '94	THERMOSTAT 55 DEGREES '94	1
33	0016 040183	SCHRAUBE FÜR KUNSTSTOFF D=4X18	SCREW FOR PLASTIC D=4X18	4

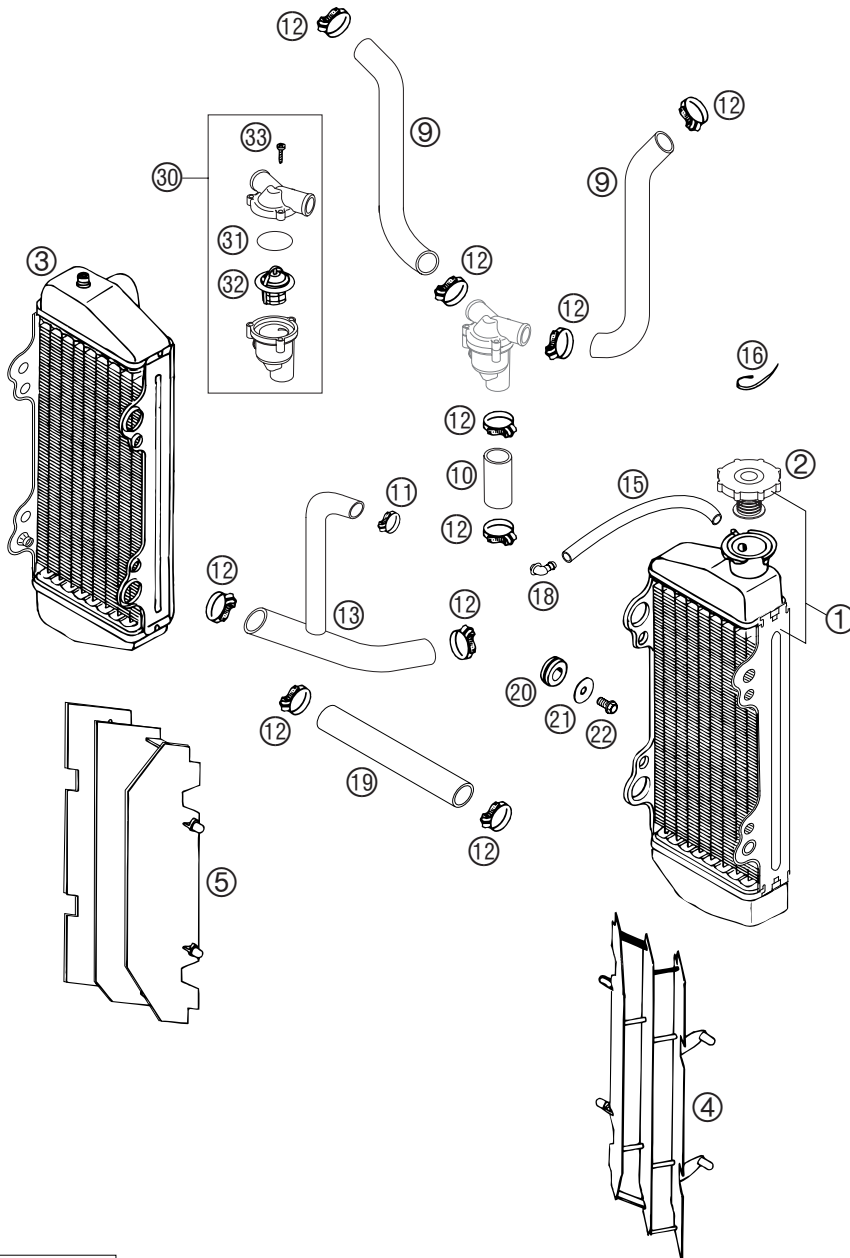

FIG	TEILNR/PARTNR	BEZEICHNUNG	DESCRIPTION	QTY
1	503.35.007.000	KÜHLER LINKS NATUR (45286) '98	RADIATOR L/S NATURE (45286)'98	1
2*	590.35.009.000	KÜHLERVERSCHLUSS 1,4 BAR 2003	RADIAT.CAP 19,6PSI (1,4BAR) 03	1
3	503.35.008.000	KÜHLER RECHTS NATUR (45285)'98	RADIATOR R/S NATURE (45285)'98	1
4	546.35.034.200	KÜHLERSCHUTZ LINKS FARBLOS '95	RADIATOR PROTECT.L/S COUL. '95	1
5	546.35.134.200	KÜHLERSCHUTZ RECHTS FARBLOS'95	RADIATOR PROTECT.R/S COUL. '95	1
9	503.35.026.100	KÜHLERFORMSCHLAUCH 125/200'99	RADIATOR HOSE 125/200'99	2
10	583.35.024.001	KÜHLERSCHLAUCH 20X26	RADIATOR HOSE 20X26	0,04
11	583.35.099.000	SCHLAUCHBINDER GEMI 10-16	HOSE CLAMP GEMI 10-16	1
12	100.01.020.000	SCHLAUCHKLEMME GEMI 16-27	HOSE CLAMP GEMI 16-27	10
13	503.35.027.100	FORMSCHLAUCH WAPU-KÜHLER '99	PREFORMED HOSE WAPU-RADIATOR	1
15	550.07.016.001	SCHLAUCH 7X10 PER METER	PVC-HOSE 7X10 PER METRE	0,17
16	440.11.076.200	KABELBAND 200MM	CABLE TIE 200MM	X
18	503.03.089.000	WINKELSTÜCK '97	ANGEL PIECE '97	1
19	565.35.025.001	KÜHLERSCHLAUCH 18X25 PER MET. KÜHLER - KÜHLER	RADIATOR HOSE 18X25 PER METRE RADIATOR - RADIATOR	0,175
20	410.01.052.000	KABELTÜLLE D=12MM	RUBBER SLEEVE D=12MM	4
21	0021 060003	SCHEIBE DIN 9021 A 6,4	WASHER DIN9021-A 6,4	4
22	0015 060123	SK.BUNDSCHRAUBE M 6X12 SW=8	HH COLLAR SCREW M 6X12 WS=8	4
30	547.35.013.044	THERMOSTATGEH.KPL.55 GRAD '99	THERMO.CASE CPL.55 DEGREES '99	1
31	0770 320020	O-RING 32,00X2,00	O-RING 32,00X2,00	1
32	546.35.017.000	THERMOSTAT 55 GRAD '94	THERMOSTAT 55 DEGREES '94	1
33	0016 040183	SCHRAUBE FÜR KUNSTSTOFF D=4X18	SCREW FOR PLASTIC D=4X18	3

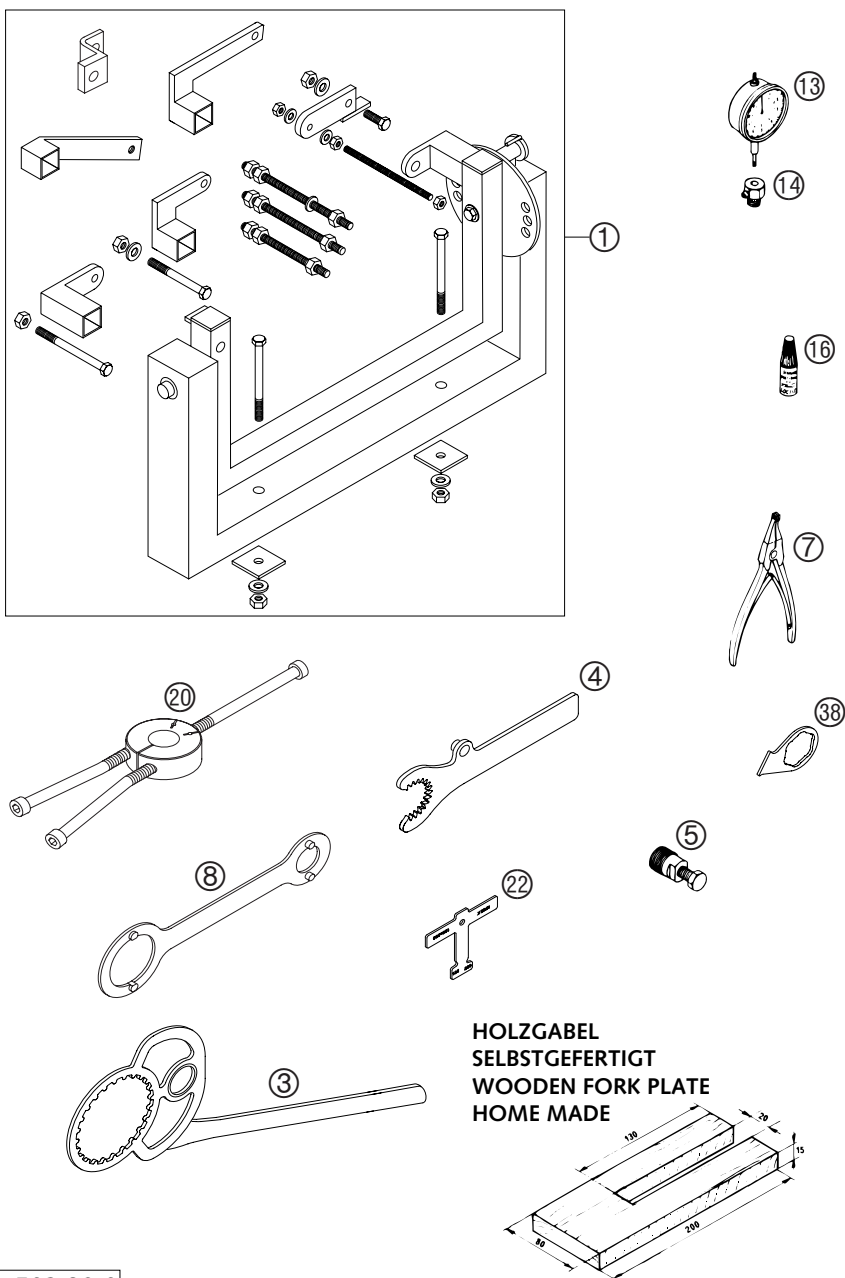
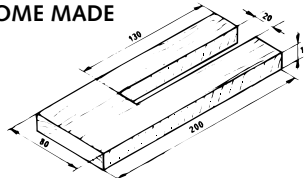

FIG	TEILNR/PARTNR	BEZEICHNUNG	DESCRIPTION	QTY
1	560.12.001.000	UNIVERSALMONTAGEBOCK '96	UNIVERSAL MOUNTING RACK '96	1
3	503.29.003.000	KUPPLUNGSHALTER 125/200 '98	HOLD. PLATE CLUTCH 125/200 '98	1
4	503.29.004.000	HALTER FÜR PRIMÄRZAHNRAD '98	HOLDER FOR PRIMARY GEAR '98	1
5	546.29.009.044	MAGNETABZIEHER M 27X1 KOKUSAN	MAGNETIC PULLER M 27X1 KOKUSAN	1
7	510.12.011.000	SEEGERRINGZANGE VERKEHRT	SPECIAL CIRCLIP PLIER	1
8	546.29.012.100	HALTESCHLÜSS. ROTOR 2K-1/2/3/4	HOLD. SPANNER ROTOR 2K-1/2/3/4	1
13	501.12.013.000	MESSUHR 0-10MM	DIAL GAUGE 0-10MM	1
14	501.12.030.000	MESSUHRHALTER	DIAL GAUGE SUPPORT	1
16	6 899 785	LOCTITE 243 BLAU 6CCM	LOCTITE 243 BLUE 6CCM	1
20	584.29.037.037	MONTAGEW.F.LAGERINNENR. NJ206	MOUNTING TOOL INNER RING NJ206	1
22	503.29.022.000	EINSTELLBLECH STEUERKLAPPE '98	SHEET METAL CONTROL FLAP '98	1
38	503.29.038.000	HALTEBLECH F. ARRETIERTR. '98	BRACKET FOR LOCATING DRUM '98	1

HOLZGABEL
SELBSTGEFERTIGT
WOODEN FORK PLATE
HOME MADE





KTM SPORTMOTORCYCLE AG
5230 Mattighofen
Austria
Internet: www.ktm.at



320882